

Improvements in LA-ICP-MS for Trace Forensic Analysis of Common Household Products Using a Short Pulse Ultraviolet Laser

Megan Mekoli

Jonna Berry, Maria Bock, Jeneé Jacobs, Stan Bajic and R. Sam Houk

Iowa State University



Overview

- Develop a method for use in forensic evidence analysis using Laser Ablation-Inductively Coupled Plasma-Mass Spectrometry (LA-ICP-MS)
- Compare **nanosecond**-LA-ICP-MS to **femtosecond**-LA-ICP-MS
 - Duct and electrical tape
 - Used in bombs and explosive devices
 - Binding during a crime
 - Copper speaker wire
 - Binding during a crime
 - Used in bombs
 - Galvanized steel pipe
 - Used to make pipe bombs and other explosive devices

LA-ICP-MS

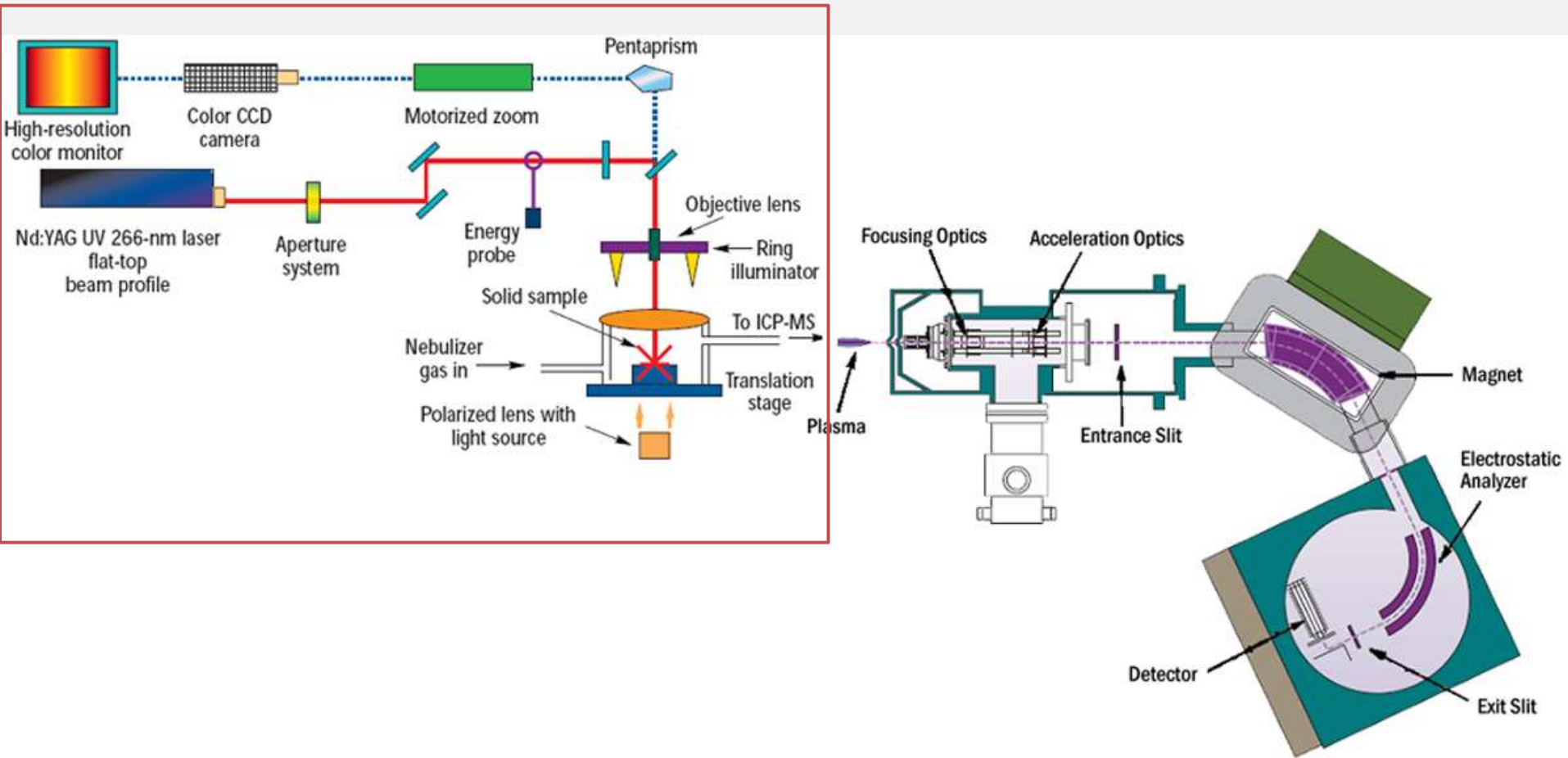

Photo courtesy of Dr. R.S. Houk,
www.thermo.com
www.cetac.com

LA-ICP-MS

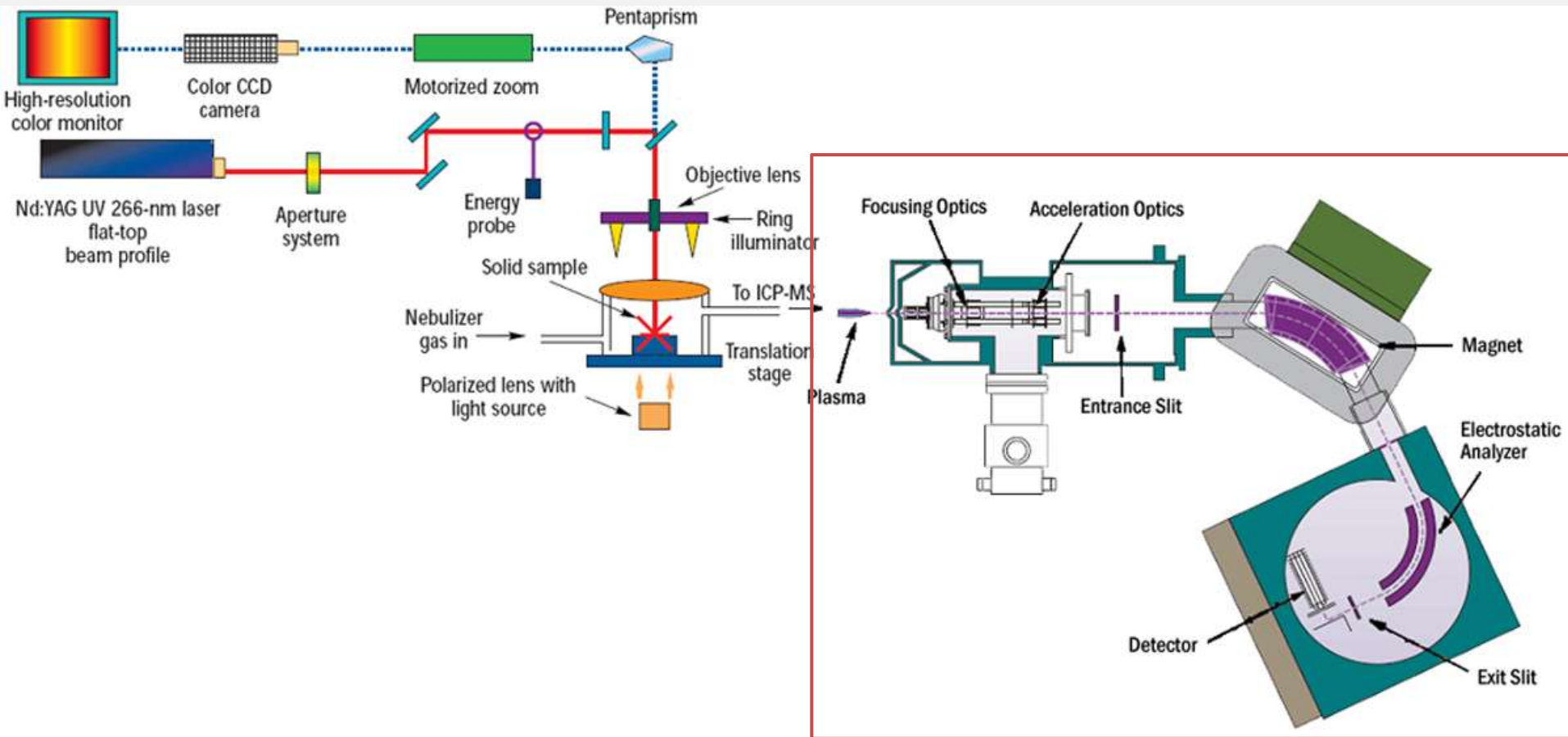

Photo courtesy of Dr. R.S. Houk,
www.thermo.com
www.cetac.com

LA-ICP-MS and Forensic Science

- Low detection limits
- Isotope abundances measurable
- Sample destruction limited
- Range of sample sizes
- Homogeneous¹
- Quantification without matrix matched standards is difficult.²

¹*Anal. Bioanal. Chem.* **2003**, 376, 1255.

²*J. Anal. At. Spectrom.*, **2003**, 18, 872.

Why Femtosecond Ablation?

- fs shorter pulse duration (~100 fs vs. 10 ns)
- Ablated particles from fs smaller, more consistent
 - ns ablated matter can contain large particles
 - Large spikes in signal, worse stability
- fs less heat transfer to sample
 - Less melting
 - Good for tapes especially
 - Less fractionation problems

Can You Tell the Difference Between These Mass Spectra?

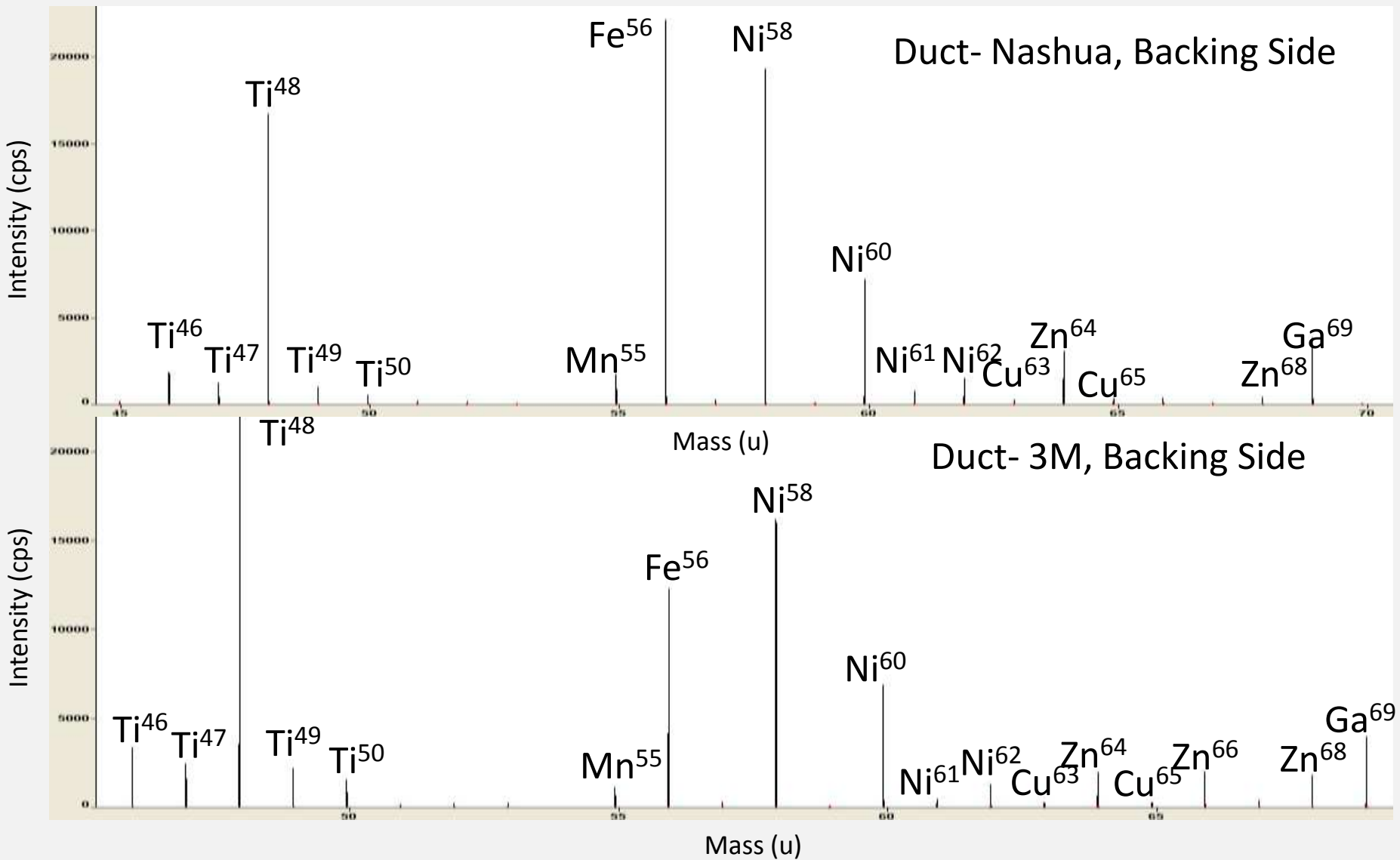

While you may be able to spot some differences by eye, what really matters are the analytical differences in the data. To quantify these differences, I'm going to use Principle Component Analysis (PCA).

PCA

- Multi-variable statistical technique
 - First consider variables (intensities) with the most variance, then second, third, etc.
 - Score
 - Plot scores
 - Eigenvector Solo 4.1 software (Eigenvector Technologies)
- Approach meant for pairwise “head-to-head” comparison analysis
- Not intended to be for attribution studies

Tapes

- Duct and Electrical Tapes
 - Often used for binding during a crime
 - Can be used in bomb making

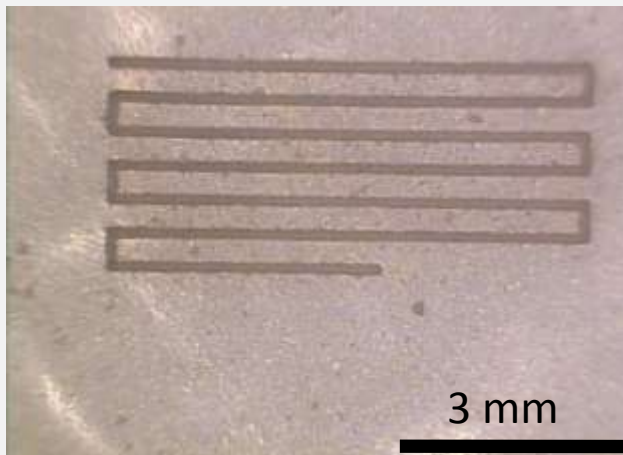
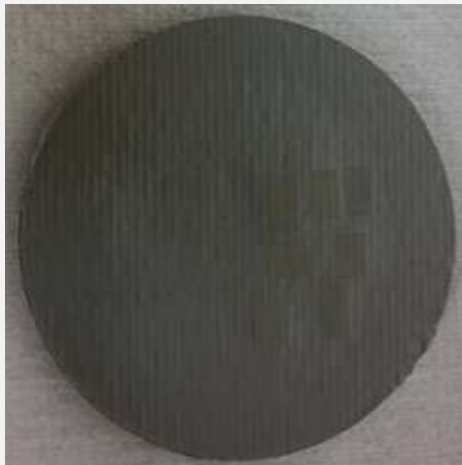

Duct- 3M, Backing Side

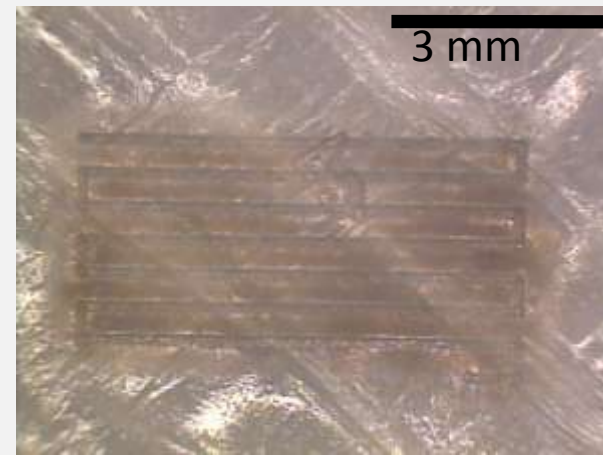

Duct- 3M, Adhesive

Method

- 1 revolution-waste
- Sample on large steel washer
– cut off excess
- Ablate backing side
- Flip, ablate adhesive side.
- 3 different samples per roll (0 ft., 3 ft., 9 ft.)

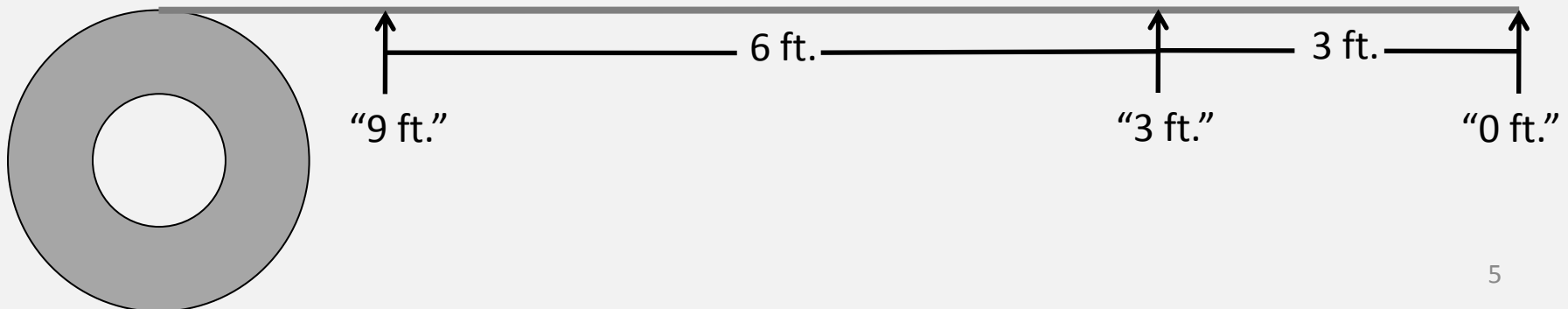
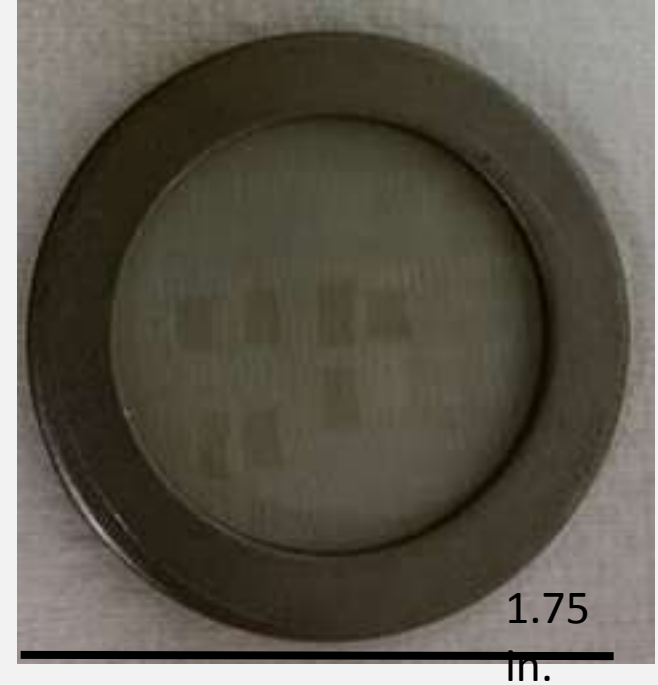

Instrumental Conditions

- Laser: CETAC LSX 500 **nanosecond** Nd:YAG (~10 ns)
 - 9.1 mJ/Pulse (100% power)
 - Frequency: 20 Hz
 - Wavelength: 266 nm
 - Spot diameter: 100 μm
 - 350 $\mu\text{m/s}$ rastering
 - This is fast to avoid ablating through the tape.
- Thermo Element 1 ICP-MS:
 - Cones: Ni
 - Medium resolution ($m/\Delta m=4000$)
 - Dual (counting and analog) mode
- Analysis: Principal Components Analysis (PCA)
 - Eigenvector Solo 4.1 Software (Eigenvector Technologies)

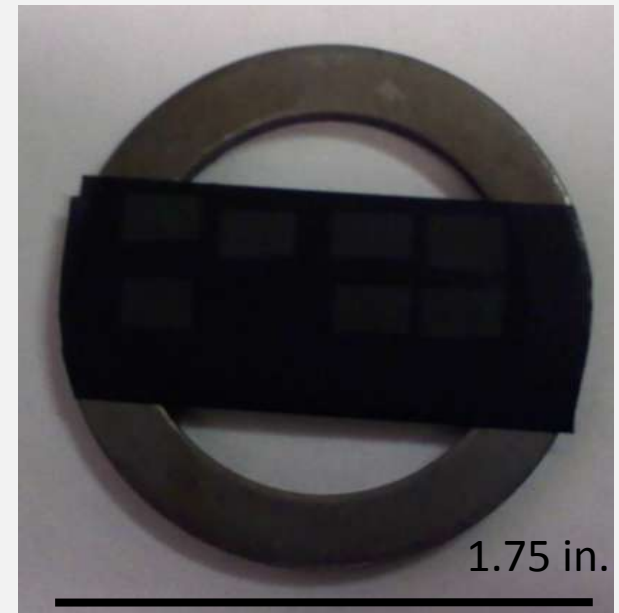

Instrumental Conditions

- Laser: COHERENT LIBRA **femtosecond** Ti:Sapphire (~100 fs)
 - 140 μ W (100% power)
 - Frequency: 1000 Hz
 - Wavelength: 266 nm
 - Spot diameter: 50 μ m
 - 300 μ m/s rastering
 - This is fast to avoid ablating through the tape.
- Thermo Element 1 ICP-MS:
 - Cones: Ni
 - Medium resolution ($m/\Delta m=4000$)
 - Dual (counting and analog) mode
- Analysis: Principal Components Analysis (PCA)
 - Eigenvector Solo 6.2 Software (Eigenvector Technologies)

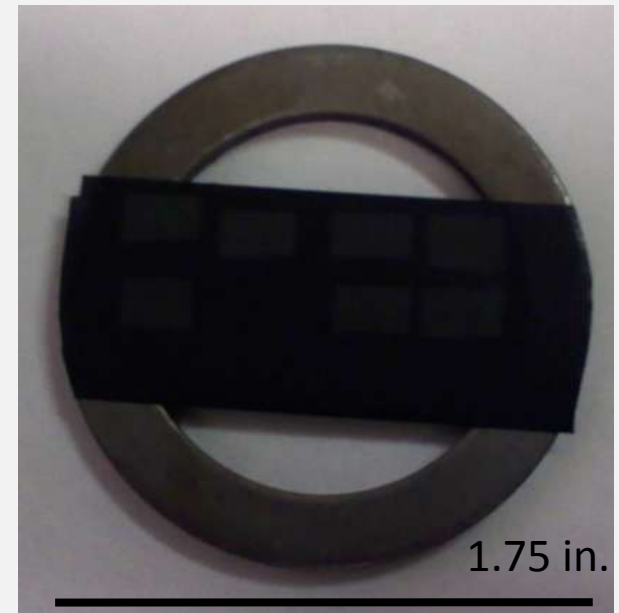

Homogeneous? PCA Plot- Duct Tape, **Backing Side**, 3M Brand

Femtosecond
Ablation

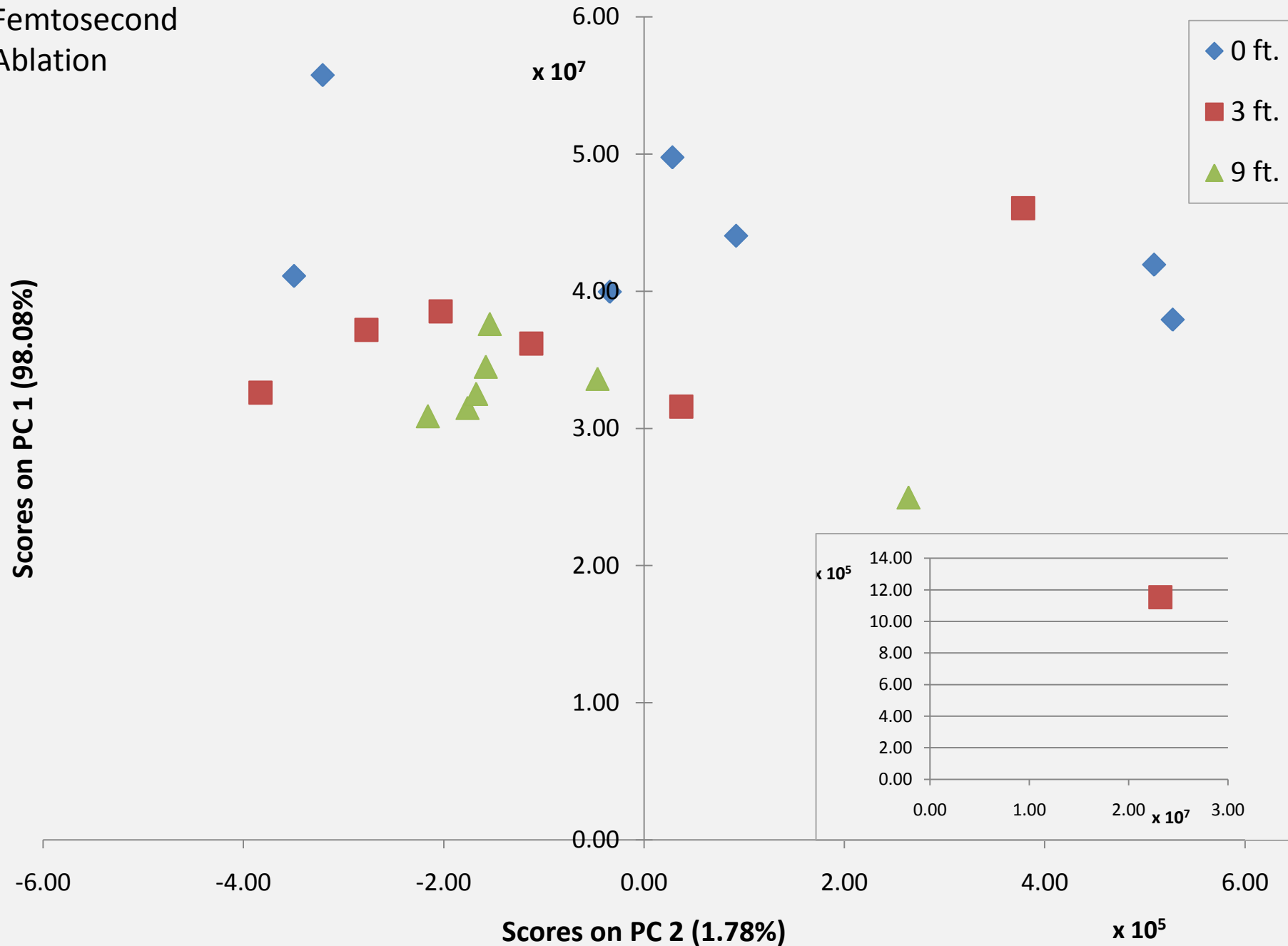

PCA Plot- Duct Tape, Adhesive Side, Duck Brand

Femtosecond
Ablation

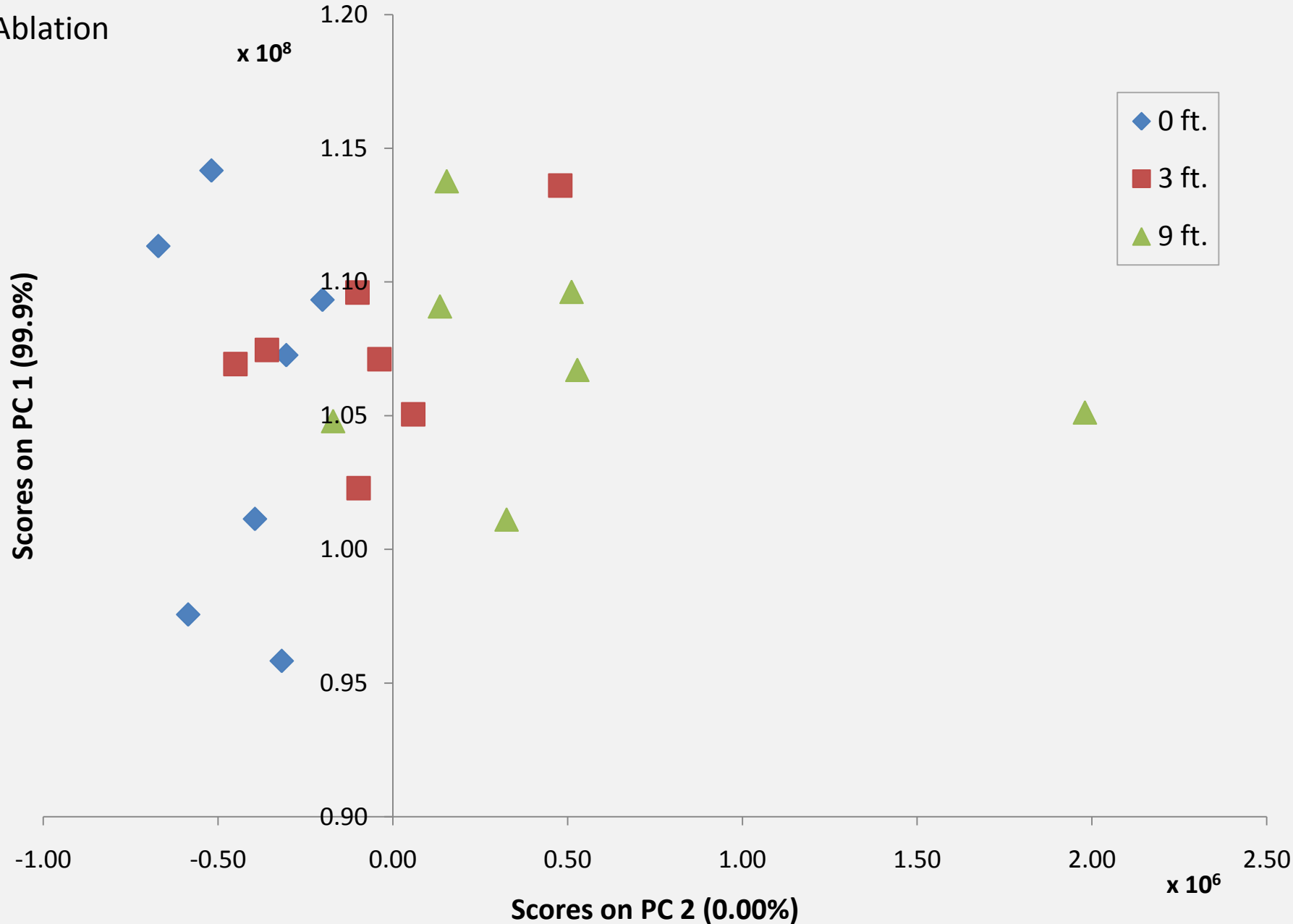

PCA Plot-Duct Tape, Backing Side

Nanosecond
Ablation

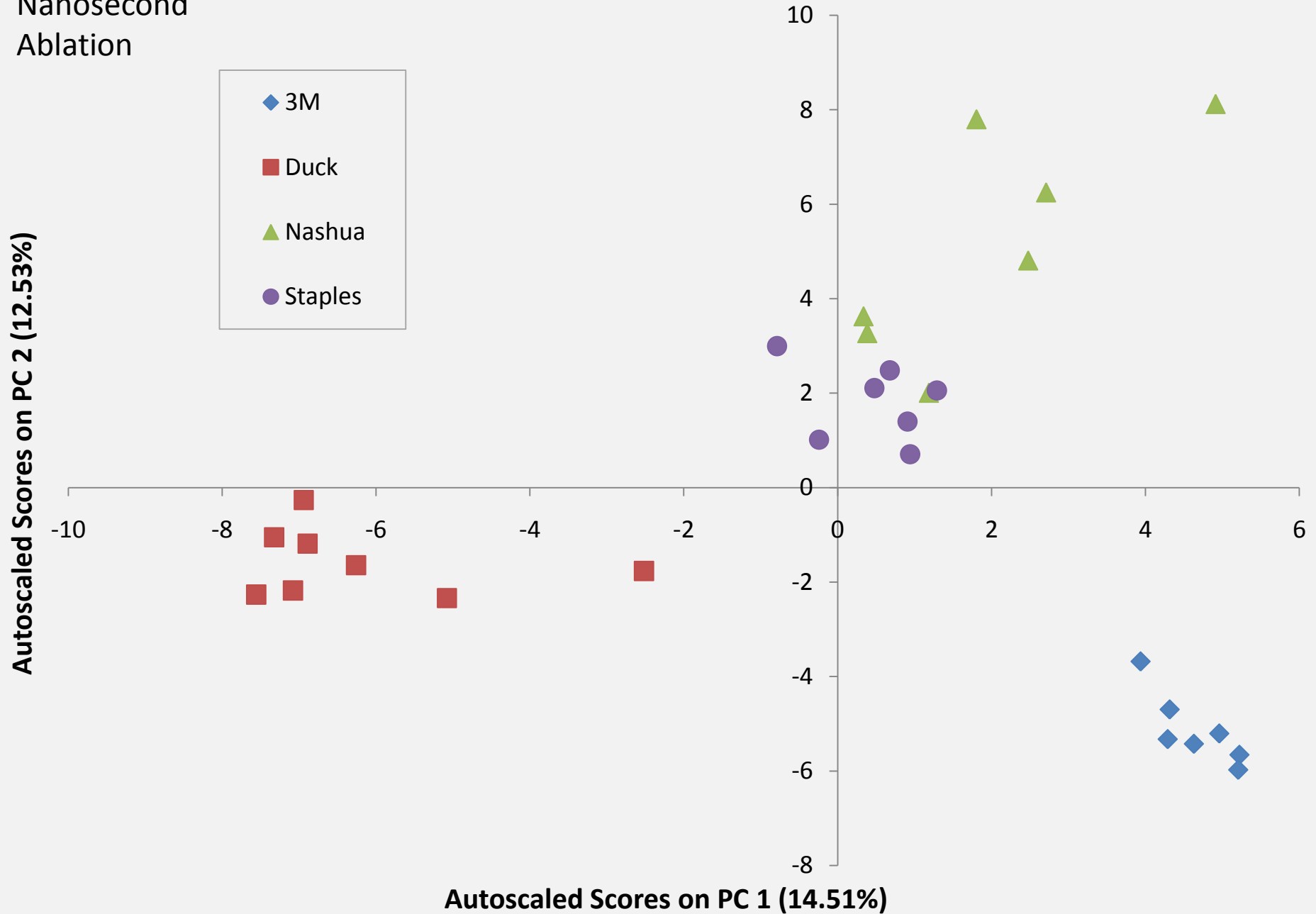

Q-Residual Plot- Duct Tape, Backing Side

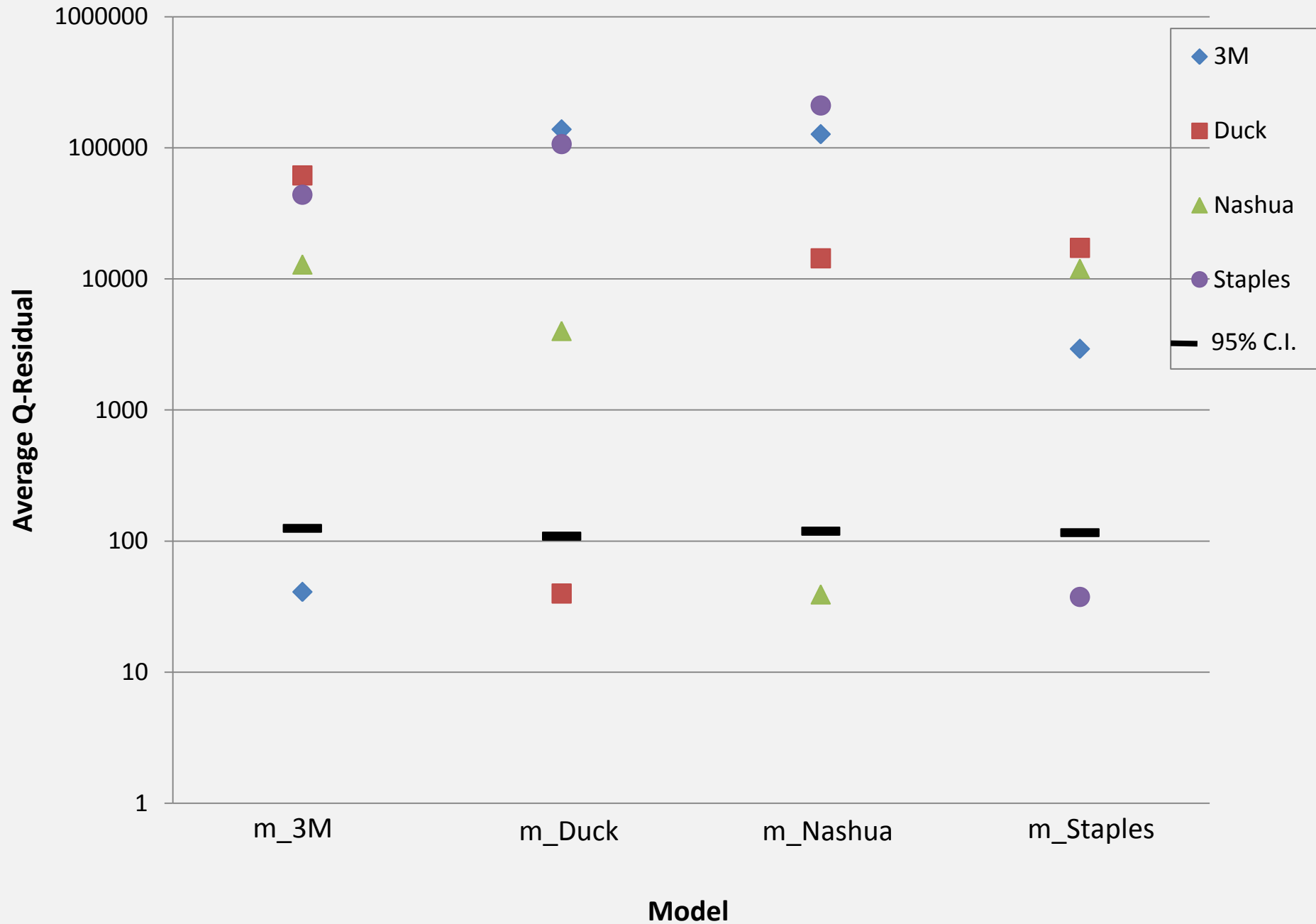

Electrical tape

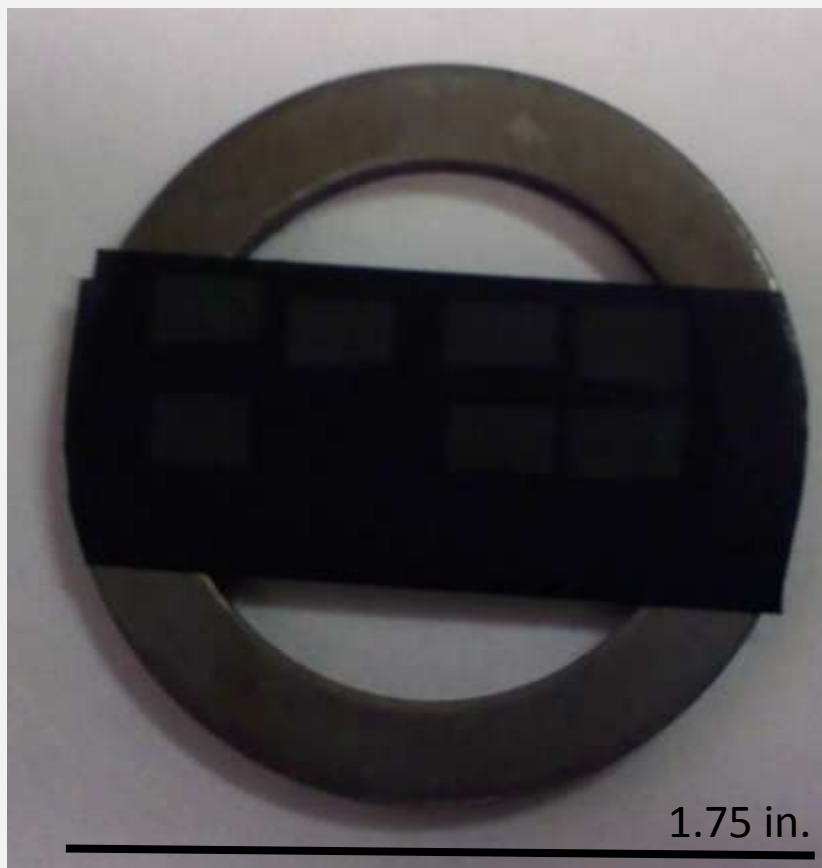

PCA Plot-Electrical Tape, Adhesive Side, UL Brand

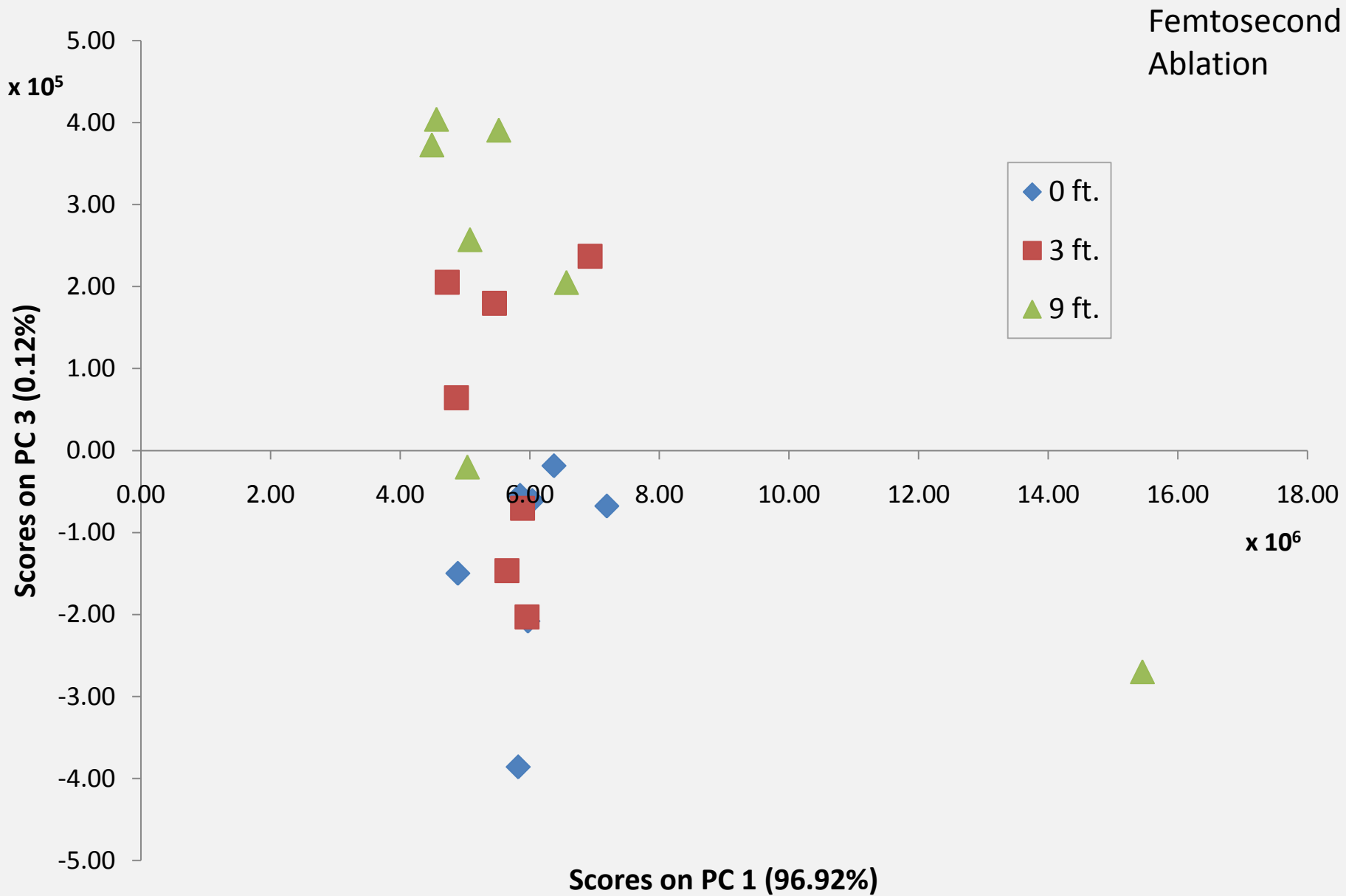

PCA Plot- Electrical Tape, Adhesive Side

Nanosecond
Ablation

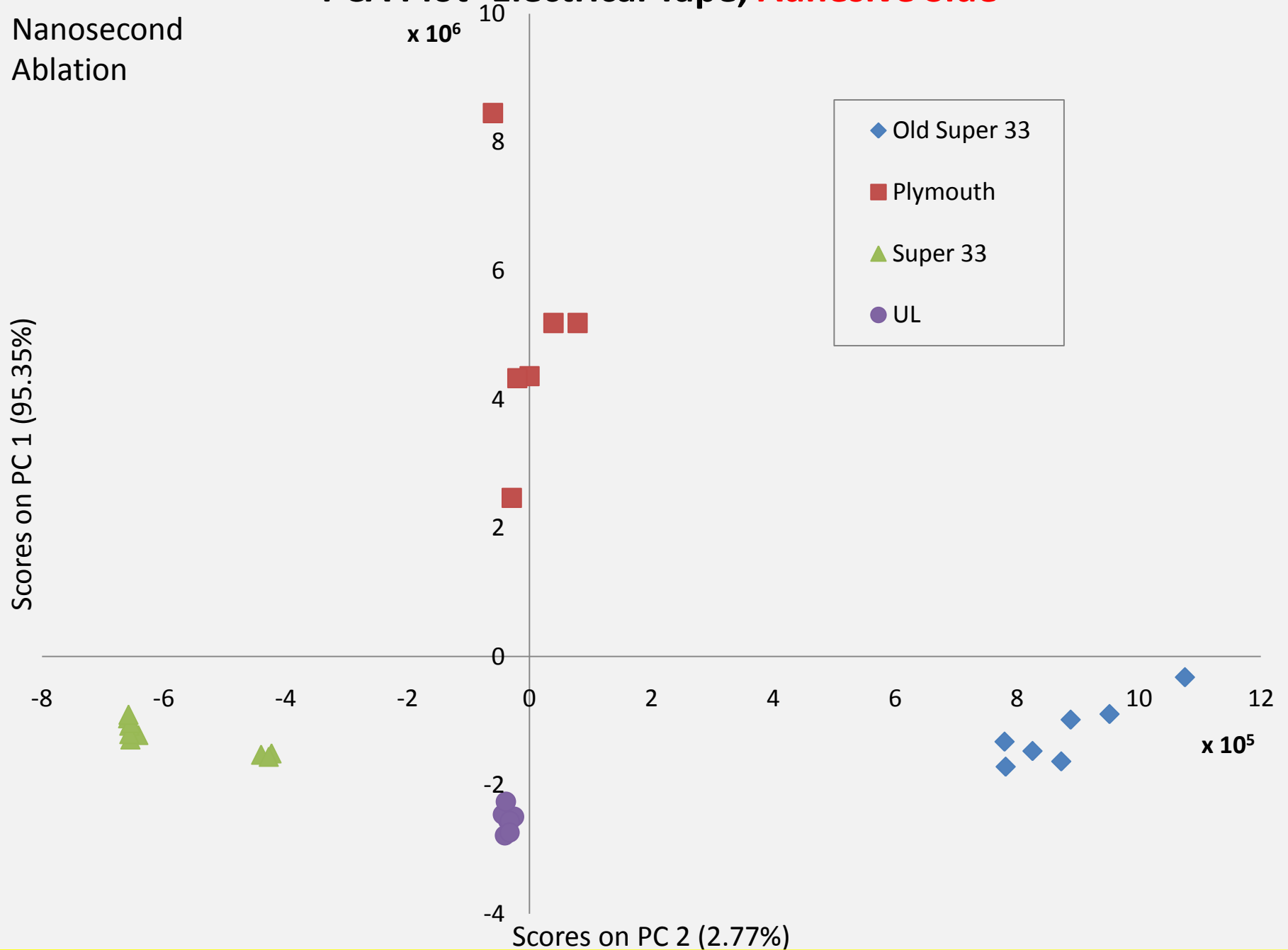

Q-Residual Plot **Adhesive Side**

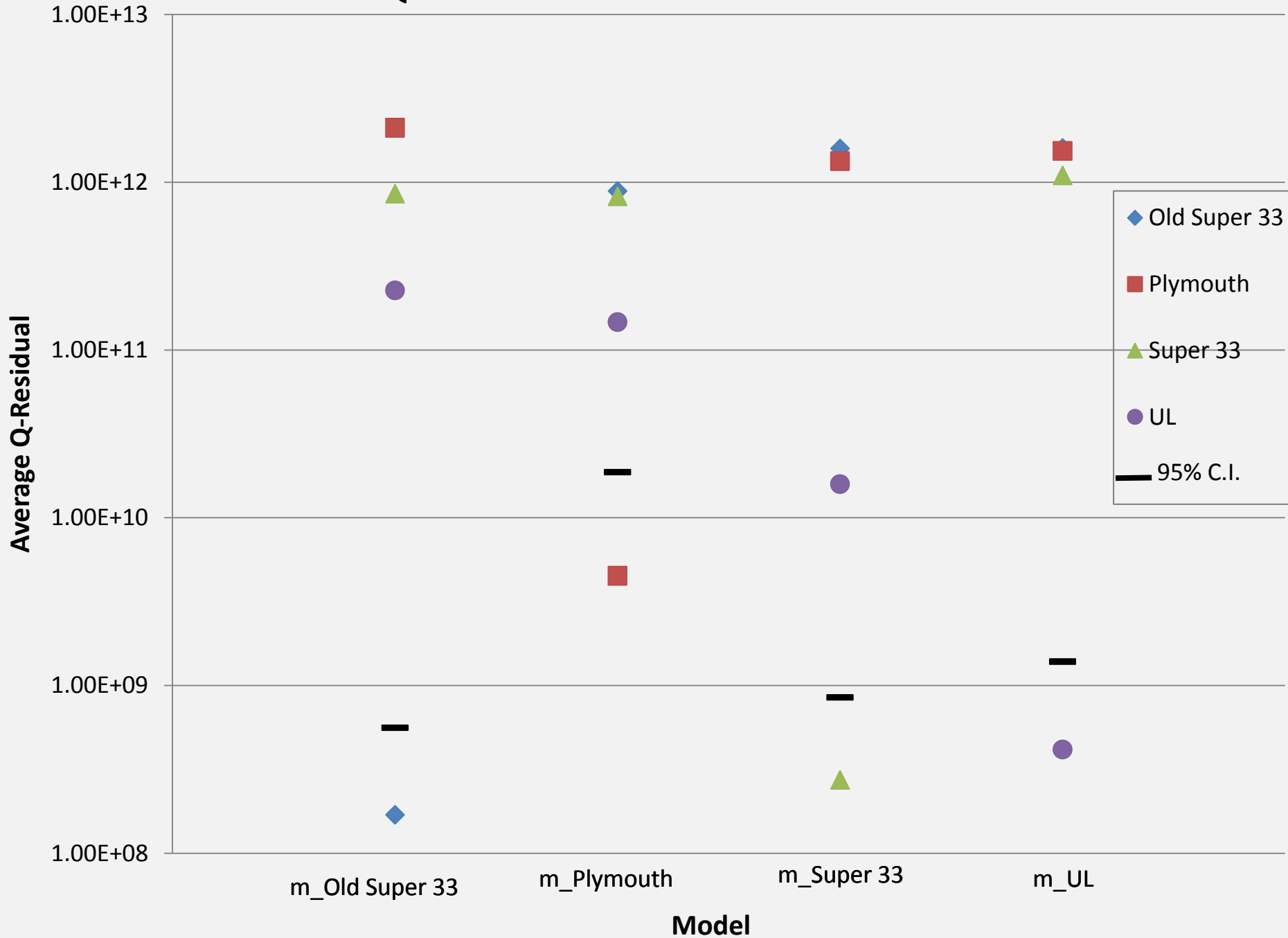

Copper Speaker Wire

- Can be used for binding in a crime
- Can be used to make bombs and explosive devices

Method

- Remove plastic coating
- Separate individual strands within the bundle
- Mount on device
- Single line ablation
 - ns ablation

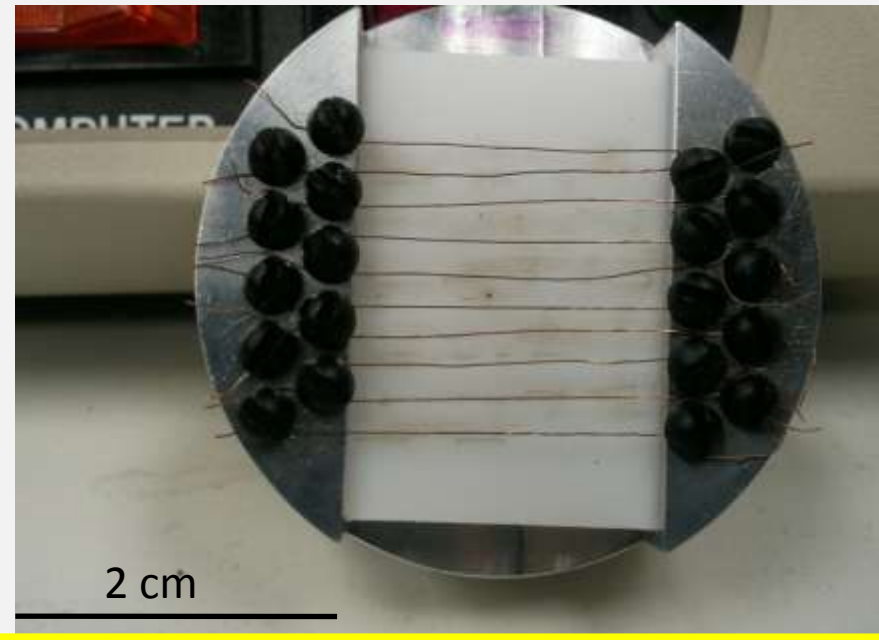

Q-Residual Plot for 10 Wires

Nanosecond Ablation

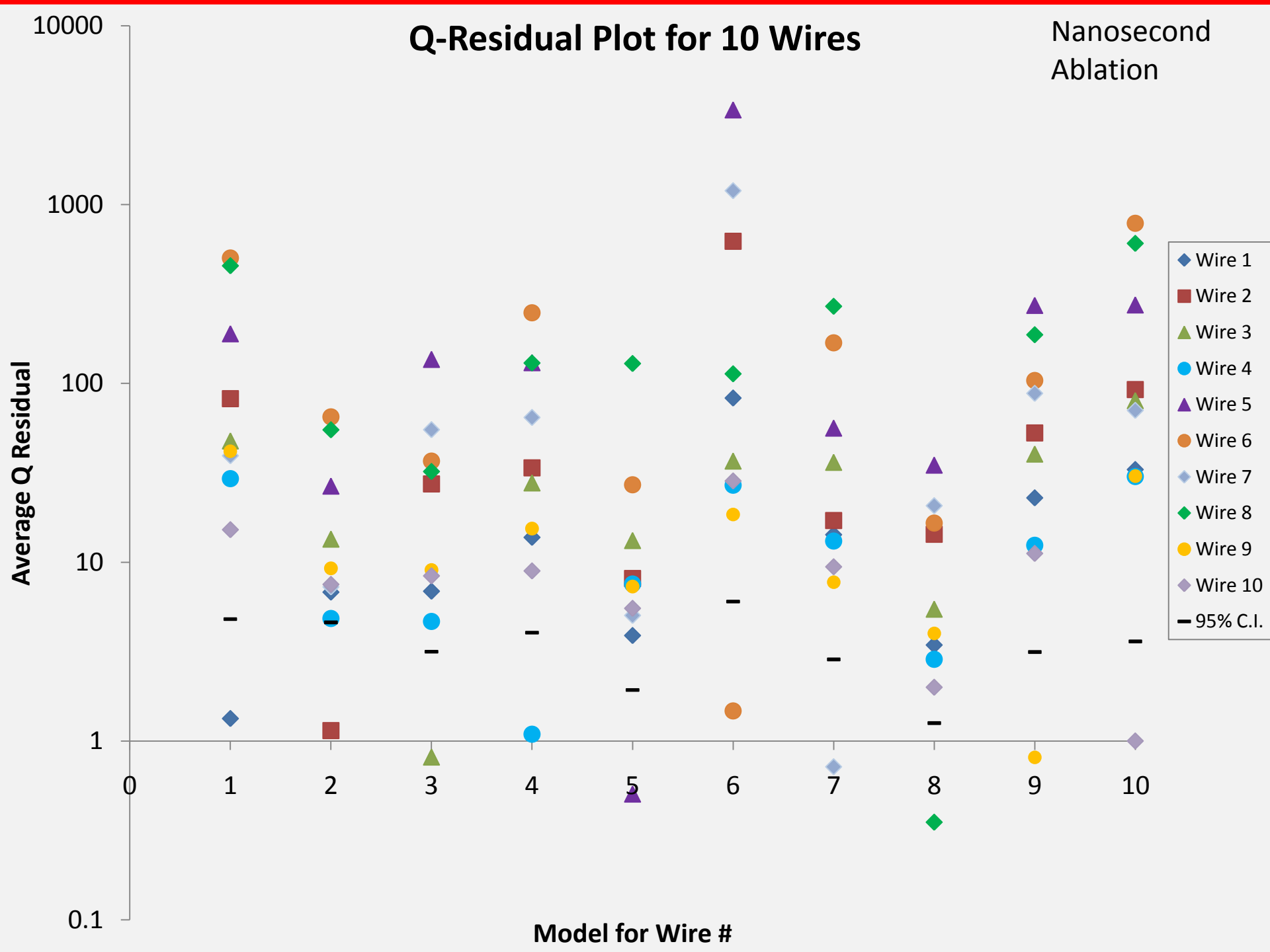

Galvanized Steel Pipe

- Commonly used for making pipe bombs and other explosive devices
- Representative for bulk metal analysis
- Steel is mostly Fe, coating is Zn
 - Coating varies by manufacturer conditions
 - Number of times dipped
 - Cooling time, temperature

Method

- Cut into pieces
- Line depth profile, ns laser

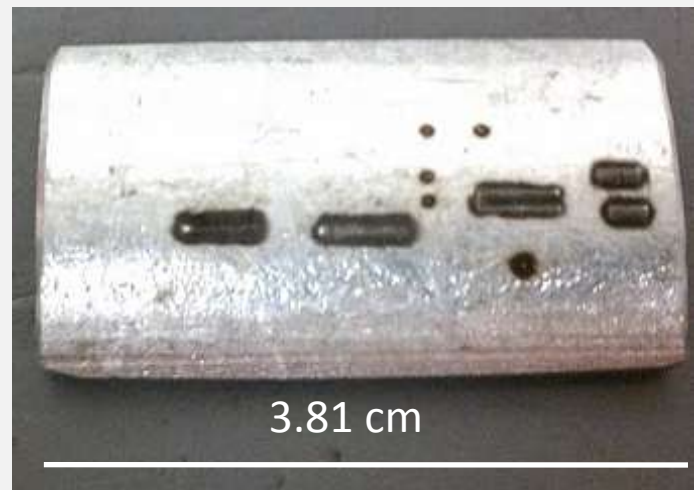

Depth Profile: Outside of Galvanized Pipe

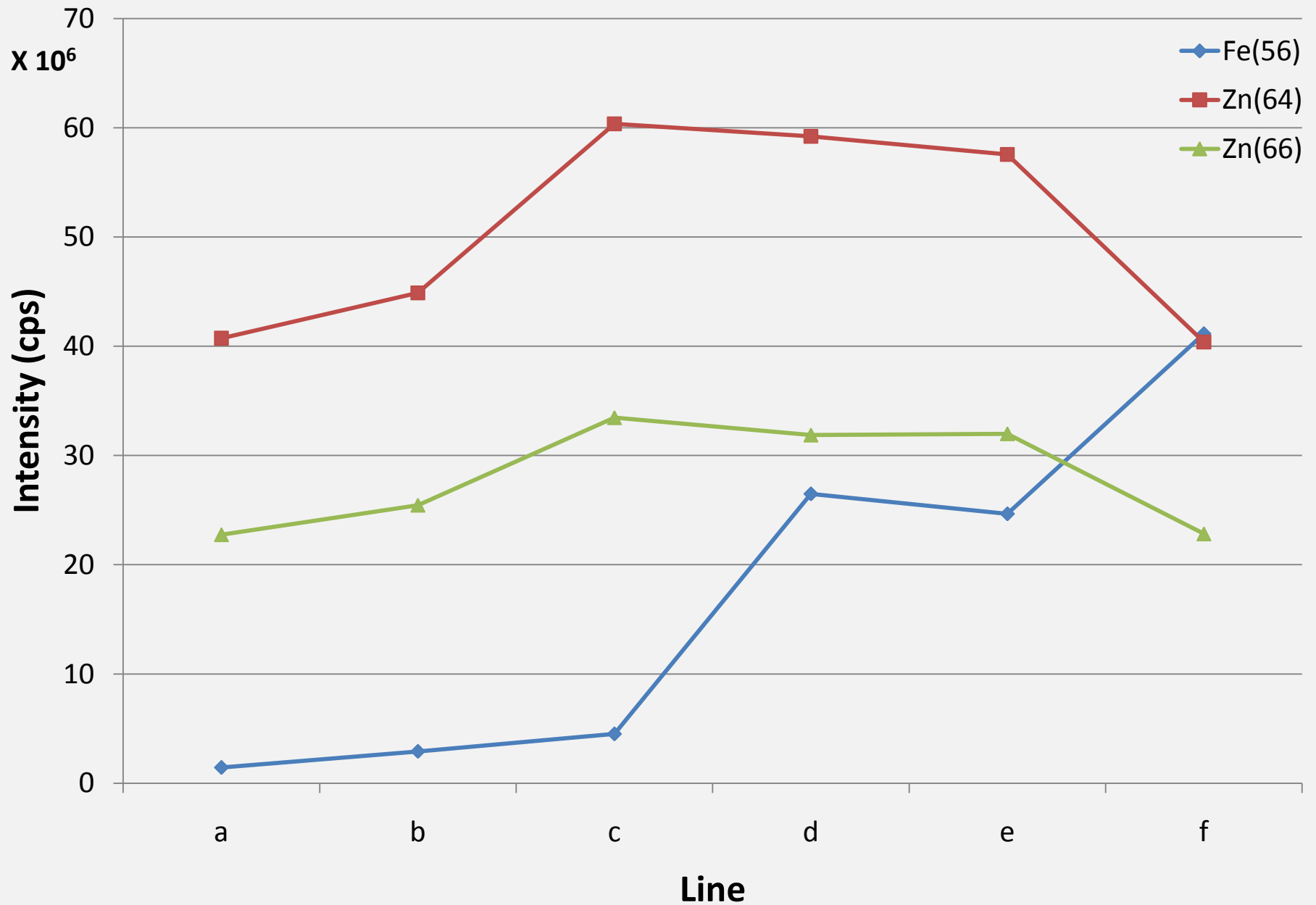

Conclusions

- Electrical and Duct tape homogeneous within roll
- Tape brands may be distinguished from one another
- Bulk copper speaker wire bundles are homogeneous within a roll
- Individual copper speaker wire strands can be distinguished from one another
 - Could allow us to do attribution studies
- Galvanized pipe coating depth may be sampled
 - Layer by layer analysis

Acknowledgments

- NIJ for the funding of this grant
- Dr. R. Sam Houk
- Dr. Stan Bajic
- Jonna Berry (copper wire)
- Maria Bock (tape)
- Jeneé Jacobs (galvanized pipe)
- Dan Zamzow