



Trace Evidence: Moving Forward

Gerry LaPorte
Office of Investigative and Forensic Sciences
National Institute of Justice

Tuesday, Aug 9, 2011
Kansas City, MO





Agenda

- NIJ and OIFS Organization and Mission
- Forensic Science Research & Development Program
- NIJ Investment in Trace Evidence Research: 2003-2010
- Trace Evidence Research Highlights – Past and Present
- 2011 General Forensics TWG – Trace Evidence Needs
- NIJ Resources

**NIJ and OIFS
Organization and Mission**





NIJ Mission and Focus

- NIJ is the research, development and evaluation agency of the U.S. Department of Justice.
- NIJ's mission is to advance scientific research, development, and evaluation to enhance the administration of justice and public safety
- NIJ provides objective, independent, evidence-based knowledge and tools.
- NIJ's research agenda is guided by the *needs of the field*. NIJ actively solicits the views of criminal justice professionals, policymakers, and researchers to identify the highest-priority research needs.



OIFS Mission

- To strengthen the quality and practice of forensic science through innovative solutions and leadership that support research and development, testing and evaluation, technology, information exchange, and the development of training resources for the criminal justice community.



OIFS Program Areas

- **Capacity Building/ Backlog Reduction**
 - Paul Coverdell Forensic Science Improvement Grants Program
 - DNA Backlog Reduction Programs (Convicted Offender, Casework)
 - Missing Persons
 - Solving Cold Cases with DNA
 - Postconviction DNA Testing Assistance

- **Training/ Technology Assistance**
 - Forensic Science Training Development and Delivery
 - Forensic Technology Center of Excellence
 - Technology Evaluations
 - Technology Transition Workshops
 - NamUs
<http://www.namus.gov/>

- **Research and Development**
 - Forensic DNA
 - General Forensics (non-DNA)



Training Awards Related to Trace Evidence

Year	Award Number	Agency	Title	Award
2007	2007-DN-BX-K207	McCrone Research Institute	Forensic Microscopy Training Program	\$496,985
2007	2007-DN-BX-K235	University of Central Florida	TWGFEX Consortium Courses	\$924,445
2008	2008-DN-BX-K071	The Florida International University Board of Trustees	Academic Workshops in Instrumental Trace Evidence Analysis	\$120,883
2008	2008-DN-BX-K181	Hooke College of Applied Sciences	Forensic Microscopy Training Program	\$684,241
2008	2008-DN-BX-K070	University of Central Florida	Explosives Analysis Training	\$520,557
2010	2010-DN-BX-K264	The Florida International University Board of Trustees	Instrumental Analysis of Trace Evidence with a Focus on Interpretation	\$298,228
2010	2010-DN-BX-K237	Hooke College of Applied Sciences	College of Microscopy Forensic Microscopy Training Delivery Program	\$911,774
			TOTAL	\$3,957,133

NIJ also funds the Scientific Working Group for Materials Analysis (SWGMAT)

**Forensic Science
Research & Development
Program**





Forensic Science R&D in OIFS

GOAL: Develop tools and technologies that can enhance or increase the capacity, capability, applicability, and/ or reliability of analysis of crime scene evidence.

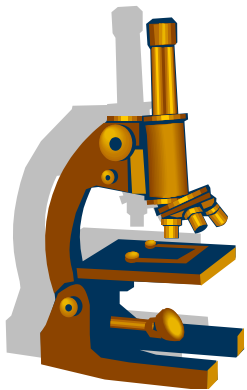



Forensic Science R&D in OIFS

Traditional Forensic Science R&D Organization

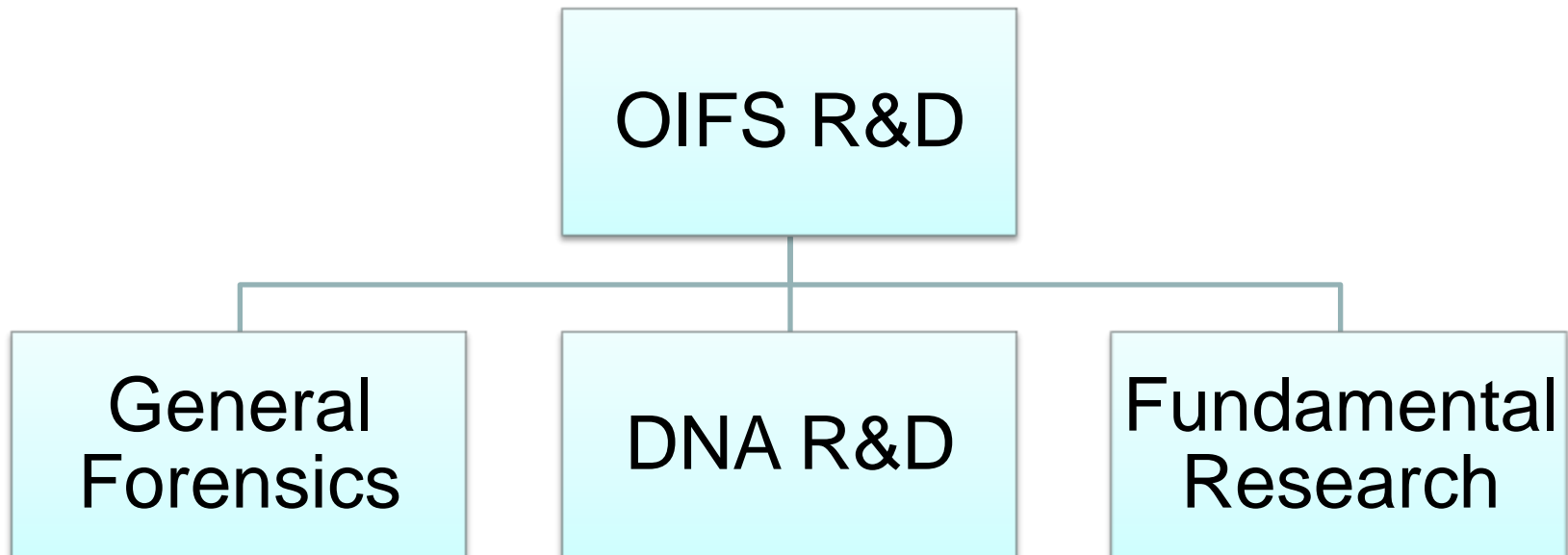



Forensic Science R&D in OIFS

Organization in Transition:
One Forensic Science R&D Team

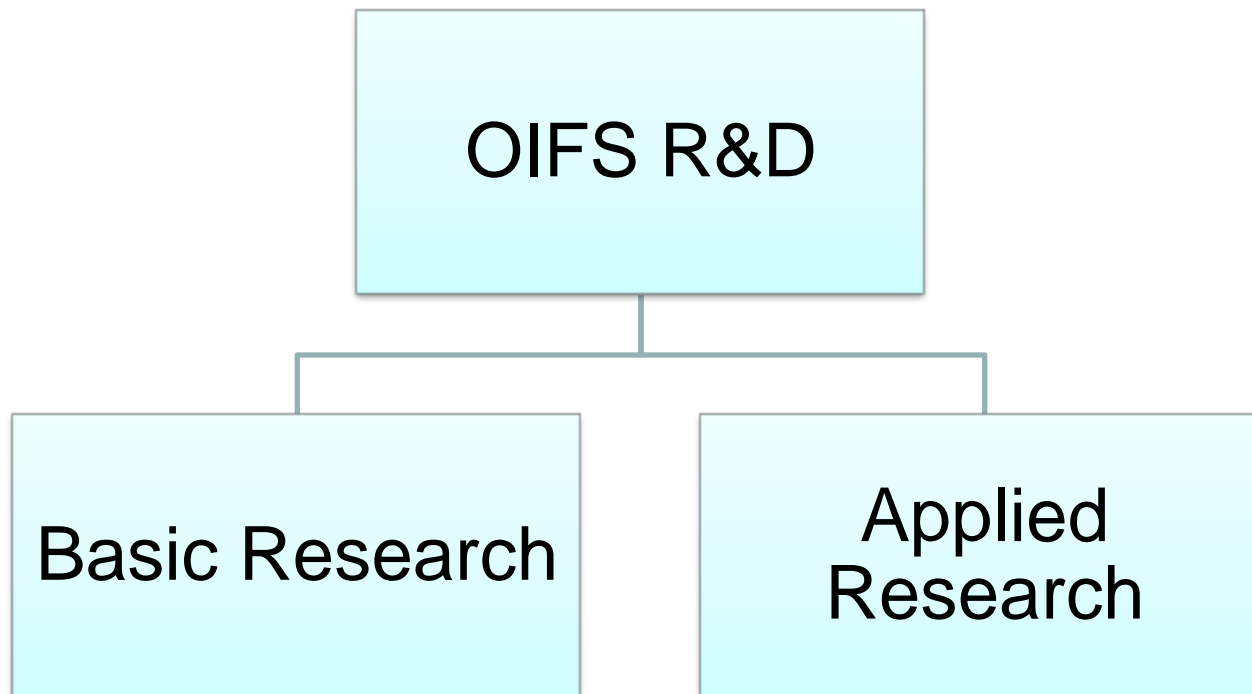



NIJ's Forensic Science R&D Funding Allocation: 2003-2010

Discipline	Funding Awarded	Percentage
Anthropology	\$5,060,989.59	8.83%
Controlled Substances	\$1,914,147.00	3.34%
Crime Scene	\$4,721,346.00	8.24%
Digital Forensics - Image Analysis	\$2,321,400.00	4.05%
Entomology	\$483,323.00	0.84%
Fire and Arson	\$4,773,017.00	8.33%
Friction Ridge	\$10,370,027.00	18.10%
Impression	\$8,332,874.00	14.55%
Pathology	\$2,833,757.00	4.95%
Questioned Documents	\$2,834,365.00	4.95%
Toxicology	\$4,623,338.00	8.07%
Trace	\$7,210,776.00	12.59%
General Forensics	\$1,810,237.00	3.16%
	\$57,289,596.59	100.00%



NIJ Investment in Trace Evidence Research by Evidence Type: 2003-2010

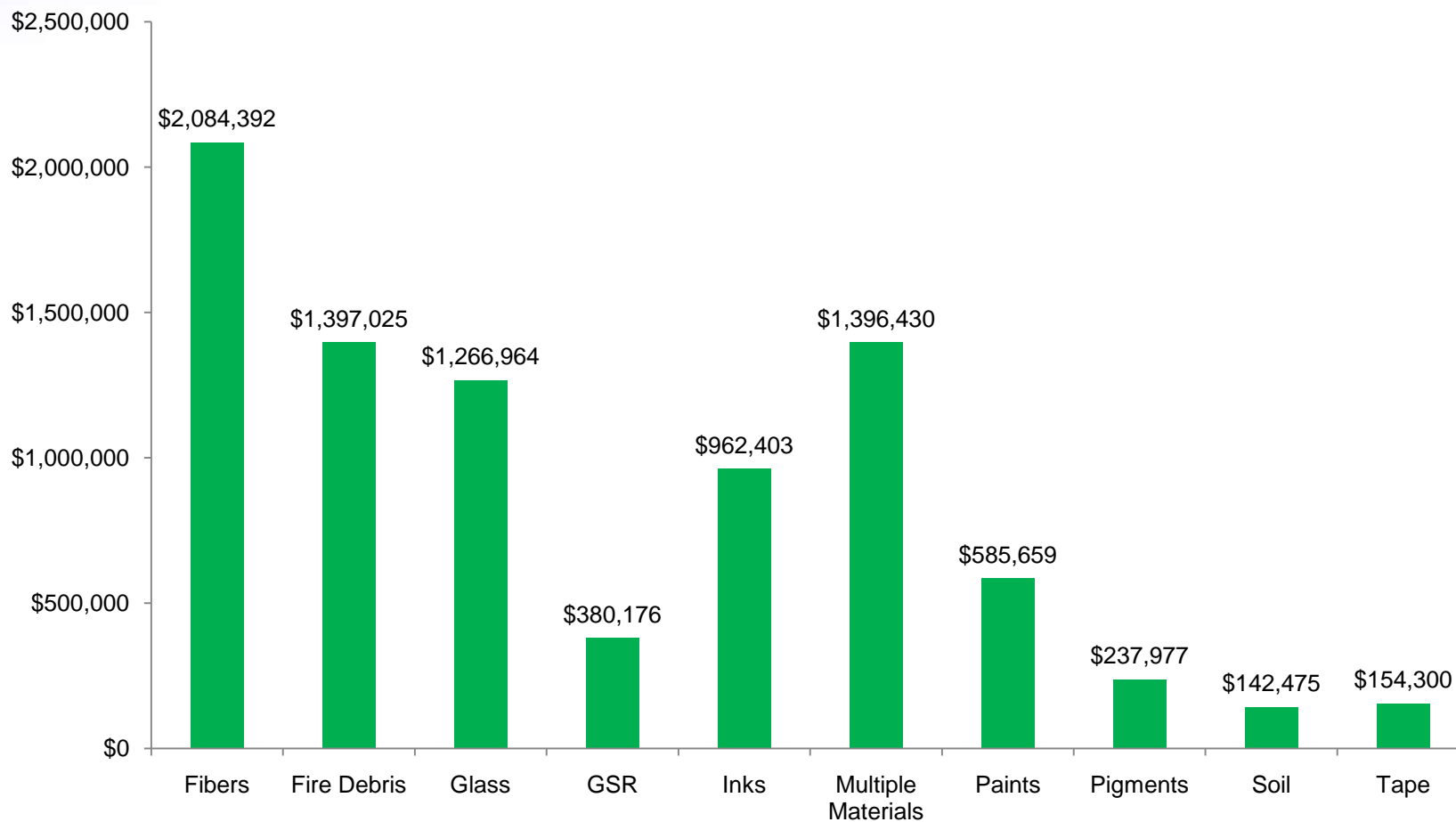



NIJ's Investment in Trace Evidence Research: 2003-2010

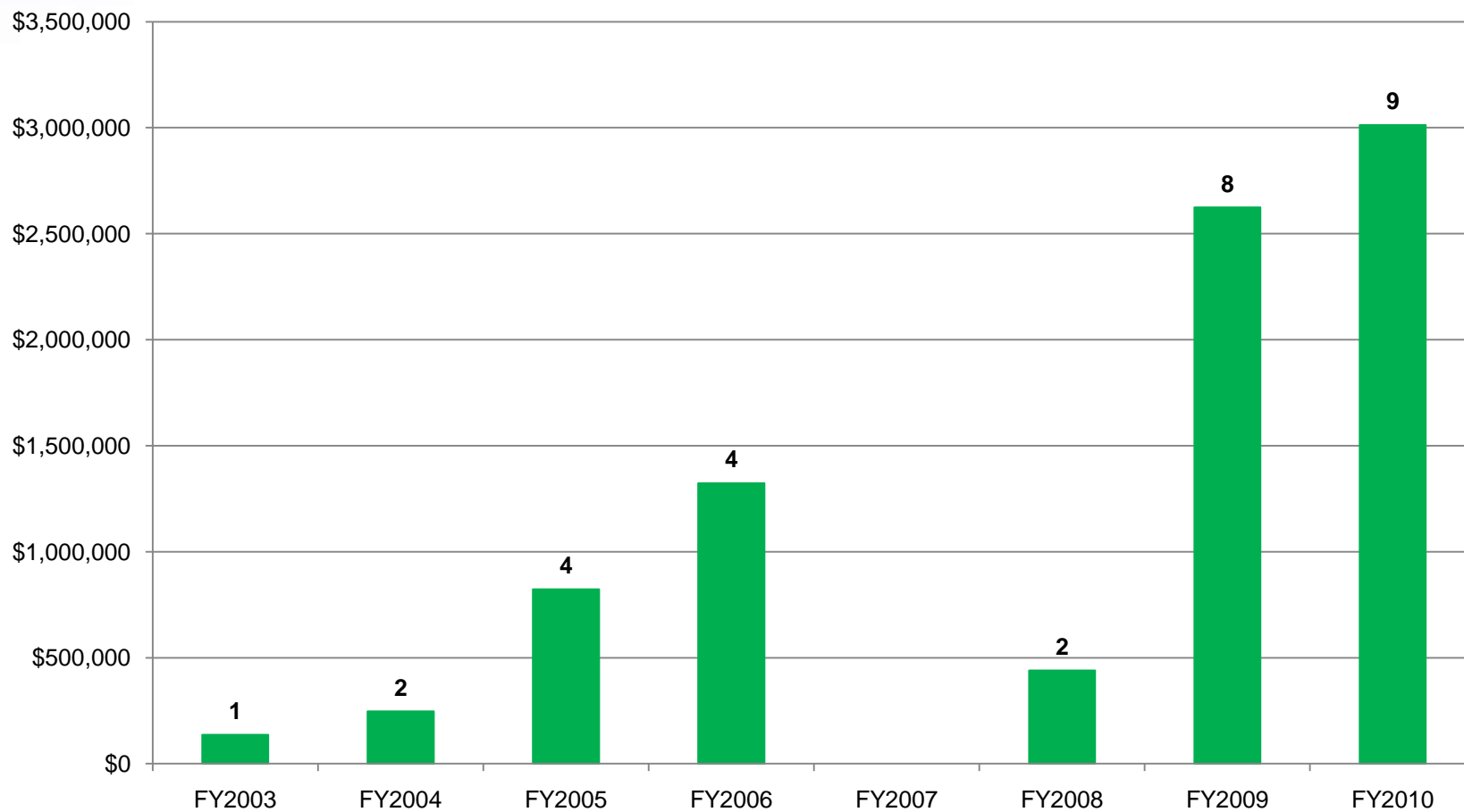



FY 2010 Forensic Science R&D Awards – Trace Evidence Portfolio

9 Projects: \$3,012,630

2010-DN-BX-K179	LA-ICP-MS and LIBS analysis of paper, inks, soils, cotton and glass	\$283,090
2010-DN-BX-K236	Fundamentals of Forensic Pigment Identification by Raman micro-spectroscopy: A practical identification guide and spectral library for forensic science laboratories	\$237,977
2010-DN-BX-K244	Use of Scanning Electron Microscopy / Energy Dispersive Spectroscopy (SEM/EDS) Methods for the Analysis of Small Particles Adhering to Carpet Fiber Surfaces as a Means to Test Associations of Trace Evidence	\$308,239
2010-DN-BX-K245	Validation of Forensic Characterization and Chemical Identification of Dyes Extracted from Millimeter-length Fibers	\$451,336
2010-DN-BX-K222	Gunshot Residue in a Non-Firearm-Related Detainee Population	\$88,837
2010-DN-BX-K272	Interpretation of Ignitable Liquid Residues in Fire Debris Analysis: Effect of Competitive Adsorption, Development of an Expert System and Assessment of the False Positive/Incorrect Assignment Rate	\$540,752
2010-DN-BX-K217	Improving Investigative Lead Information and Evidential Significance Assessment for Automotive Paint and the PDQ Database	\$460,473
2010-DN-BX-K220	Evaluation of Statistical Measures for Fiber Comparisons: Interlaboratory Studies and Forensic Databases	\$489,049
2010-DN-BX-K219	Determination of Unique Fracture Patterns in Glass and Glassy Polymers	\$152,877

2011 General Forensic Technology Working Groups (TWG)

Trace Evidence Needs





Purpose of Forensic Science TWGs

- Identify and document research and technology needs of the forensic science community
 - Needs and requirements identified serve as the basis for NIJ's Forensic Science Research & Development solicitations
- Evaluate current portfolio projects
- Review and rank annual technology evaluation proposals



General Forensics R&D TWG

- Divided into 3 sub-TWGs
 - Crime Scene and Medicolegal Death Investigation
 - Pattern and Impression Evidence
 - Instrumental Analysis
- 2011 Winter Meeting Outcome
 - January 13-14 in Alexandria, VA
 - Twenty-nine (29) High Priority Needs
 - Seventeen (17) Medium Priority Needs
 - One (1) Low Priority Need



TWG Needs Related to Trace Evidence: High Priority

- Statistical validation studies of evidence detection and significance of evidence.
- Databases for new materials and the continuing update of databases
 - Lack of reference information for new products/materials
 - Eco-fibers, pigments, glass formulations, adhesives
- Development of validated methods that are inexpensive, more accessible, and/or more effective or sensitive.



TWG Needs Related to Trace Evidence: High Priority

- Develop new tools and techniques that enhance the visualization of trace evidence found at crime scenes.
- Develop new techniques for the detection, recognition, and recovery of materials with emphasis on imaging techniques and automation of some of the processes.
- Evaluation of different instrument platforms for different commonly encountered materials.
 - Identify best practices for material identification among emerging technologies



TWG Needs Related to Trace Evidence: High Priority

- Methods for assisting interpretations of qualitative analysis, and integration of statistical methods with instrumentation.
 - Make qualitative and semi-quantitative analyses of analytical data more objective and standardized.
 - E.g., Cotton fiber analysis; what makes a match?
- Instrumental and statistical evaluation of the significance of evidence.
 - Need for forensically-relevant tools for statistical interpretation of evidence.



TWG Needs Related to Trace Evidence: Medium Priority

- Better technology to analyze gunshot residue.
 - Research study on GSR (primer residue on hand) to study its validity and probative value.
 - Other methods to determine if an individual handled a firearm.
- Develop automation for frequently conducted sample preparation and analysis.
 - Streamlined processes



TWG Needs Related to Trace Evidence: Medium Priority

- Studies to determine and compare the exclusionary value of [1] microscopic hair comparisons, [2] mtDNA analysis, and [3] when the two techniques are combined.
 - Lack of understanding in the Criminal Justice system of the value of microscopic hair analysis.
- Support instrumentation development and determine forensic applications of existing and emerging technologies.
 - e.g., hyperspectral imaging, microspectrophotometry, fast-GC and 2-D GC.



TWG Needs Related to Trace Evidence: Medium Priority

- Develop instrumental methods for the further characterization and discrimination of polymers
- Improve the testing and understanding of weathered materials to determine how environmental effects can affect analysis.



NIJ Research: Web Sources

- Final Technical Reports
 - Abstract, Relevant Literature, Methods, Data Collection and Analysis Procedures, Modifications, Findings and Conclusions
 - National Criminal Justice Reference Service (NCJRS)

- NIJ Forensic Science Topic Pages

<http://nij.gov/topics/forensics/welcome.htm>



TRACE EVIDENCE

Research and Development Projects

RELATED CONTENT

[Trace Evidence Symposium](#)

[Types of Forensic Evidence](#)

[Types of Forensics Investigations](#)

[Crime Laboratory Operations](#)

[Training: Forensics](#)

Viewing some content on this page may require a [free plugin application](#).

Trace Evidence: Research and Development Projects

The following table — Trace Evidence Research and Development Awards, 2004–2010 — shows awards made by NIJ for trace evidence research and development projects.

Both ongoing and completed projects are included. Project titles for completed awards are linked to the substantive report submitted to NIJ at the completion of the project if available.

[See also the abstracts for all fiscal year 2009-2010 forensic research and development awards \(pdf, 205 pages\).](#)

Trace Evidence Research and Development Awards, 2004–2010

Project Title (linked to final report if available)	Awardee	Award Number	Amount [1]
Use of Scanning Electron Microscopy / Energy Dispersive Spectroscopy (SEM/EDS) Methods for the Analysis of Trace Evidence	Stoney Forensic, Inc.	2010-DN-BX-K244	\$308,239
LA-ICP-MS and LIBS Analysis of Paper, Inks, Soils, Cotton and Glass	The Florida International University	2010-DN-BX-K179	\$283,090
Fundamentals of Forensic Pigment Identification by Raman Micro-Spectroscopy: A Practical Identification Guide and Spectral Library for Forensic Science Laboratories	Microtrace, LLC	2010-DN-BX-K236	\$237,977
Validation of Forensic Characterization and Chemical Identification of Dyes Extracted From Millimeter-Length Fibers	University of South Carolina Research Foundation	2010-DN-BX-K245	\$451,336
Gunshot Residue in a Non-Firearm Related	Harris County	2010-DN-BX-K246	\$88,837

- Text size:
- [Print this page](#)
- [E-mail this page](#)
- [Feedback](#)
- [Subscriptions](#)

TRAINING

- [Trace Evidence Symposium](#)
- [Training courses](#)



NIJ Research: Technology Transition

- Technology Transition Workshops
 - Transfer of knowledge of emerging technologies with forensic applications from researcher to practitioner
 - Hosted by the Forensic Technologies CoE
http://projects.nfstc.org/tech_transition/
 - Technology Evaluations
<http://www.ojp.usdoj.gov/nij/topics/technology/research-development-process.htm#phase4>



Thank You!

Questions

