



Technology Transition Workshop | *Steven A. Hofstadler, Ph.D.*

Introduction to Biological Mass Spectrometry ***(Mass Spectrometry 101)***

Disclaimer

- **This presentation covers the basic concepts of mass spectrometry**
- **Intimate knowledge of this material is not specifically required to operate the Ibis platform**
- **Users are not expected to tune and/or optimize the mass spectrometer**
- **The goal of this presentation is to give the user a basic understanding of where/how mass spectrometry fits into the Ibis workflow**

Overview

- **Introduction – what is mass spectrometry?**
 - Mass spectrometry (MS) and Ibis™ PLEX-ID™
- **Brief history**
- **General components**
- **The “mass” spectrum**
 - Definitions and nomenclature
- **Ionization sources**
 - Matrix Assisted Laser Desorption Ionization (MALDI)
 - Electrospray Ionization (ESI)
 - Others
- **Time-of-Flight (TOF) mass analyzers**
- **ESI-TOF of nucleic acids**

Mass Spectrometry and Ibis™ Platform

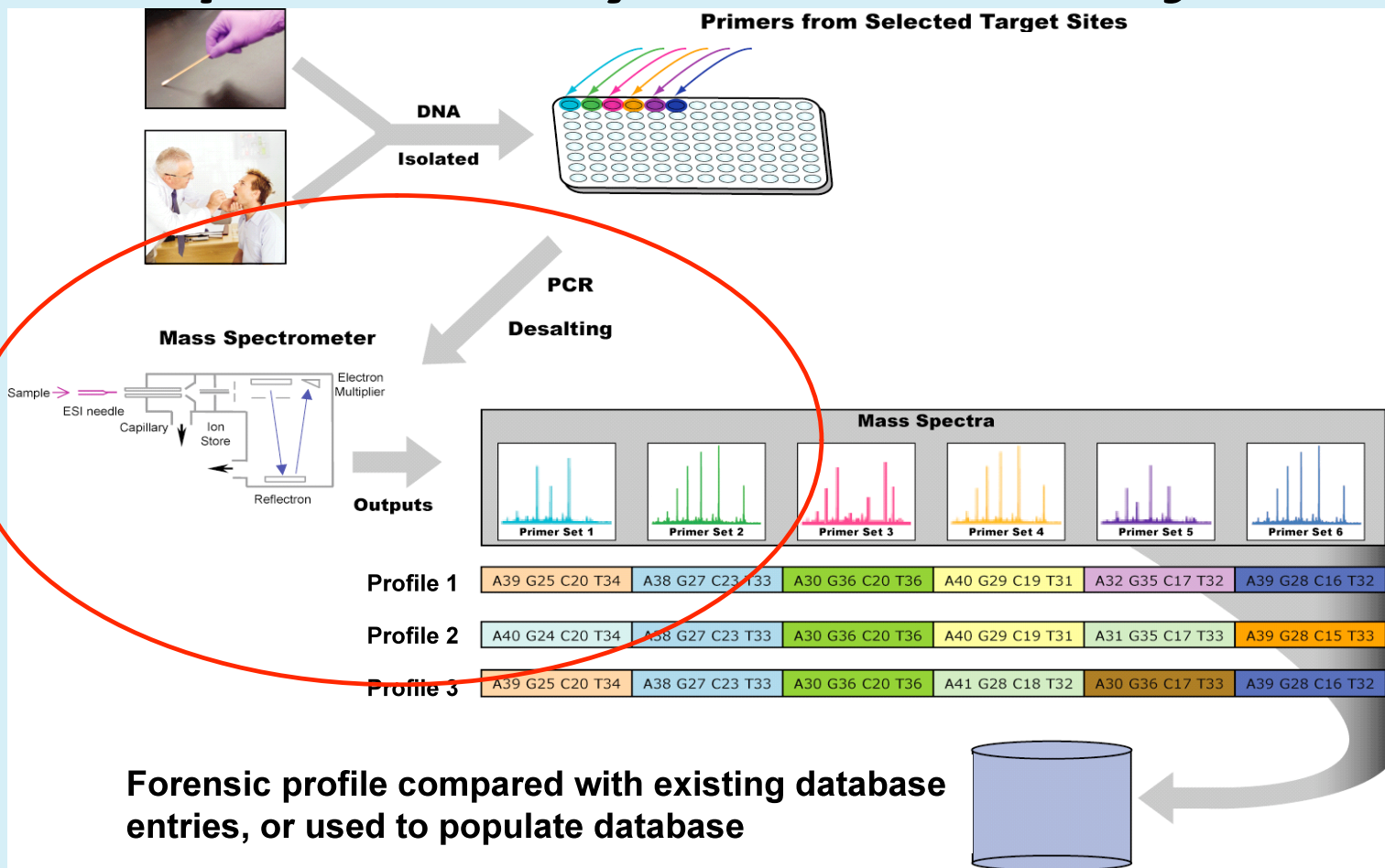

Mass Spectrometry of Nucleic Acids?

- **Information content**
 - From precise mass measurements unambiguous base compositions are derived [A10 G23 C32 T17] = [10 23 32 17]
- **Speed**
 - ≤ 1 minute/sample
- **Applicability to mixtures**
 - MS succeeds where sequencing fails (e.g. mixtures)
- **Automation**
 - End-to-end process is highly automated (including spectral processing/interpretation)
- **Sensitivity**
 - Single copy detection demonstrated with PCR front-end

What is a Mass Spectrometer?

- **An instrument which measures the mass-to-charge ratio (m/z) of ionized analyte based on its response to applied electric and/or magnetic fields**
 - **Atoms, molecules, clusters, and macromolecular complexes**
- **The m/z measurement is converted to a mass measurement**
 - **m is in atomic mass units or Daltons (Da)**
 - **1 Da = 1/12 the mass of a single atom of ^{12}C**
 - **1 Da = 1.66×10^{-24} grams**
 - **z is an integer multiplier of the fundamental unit of charge (q)**
 - **$q = 1.602 \times 10^{-19}$ Coulombs**
 - **Mass = $(m/z) \times (z)$**
- **A mass spectrometer is essentially a “molecular (or atomic) scale” that “weighs” analytes of interest**

Brief History

- 1897 J.J. Thompson announced the presence of electrons or “corpuscles” based on the deflection of cathode rays by electric and magnetic fields
- He later used this “beam-deflection device” to measure the mass of the electron (1906 Nobel Prize)



Image courtesy of <http://www.manep.ch/img/photo/challenges/nanotubes/thompson.jpg>

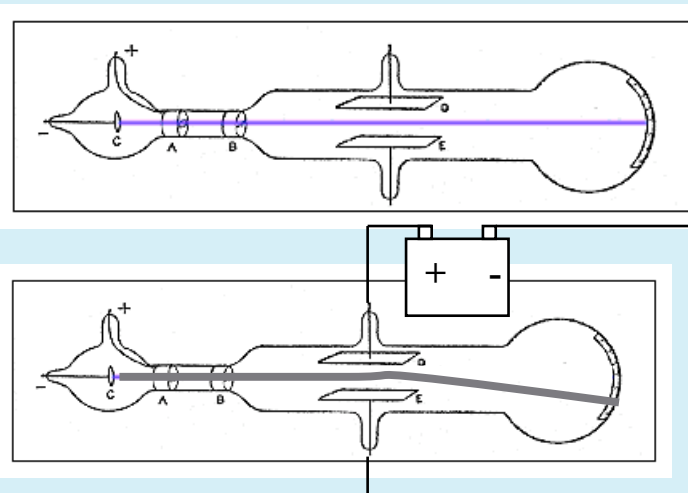

Technology
Transition Workshop



Brief History (continued)

- 1919 F.W. Aston used Thompson's mass spectrometer to measure the atomic masses of 30 gaseous elements and prove the existence of multiple isotopes
- Relative abundance measurements were made by recording isotope lines on film
- "Mass spectroscopy" (1922 Nobel Prize) (Nature 104, 393 (1919))
 - Design principles are the basis of modern electric and magnetic sector instruments

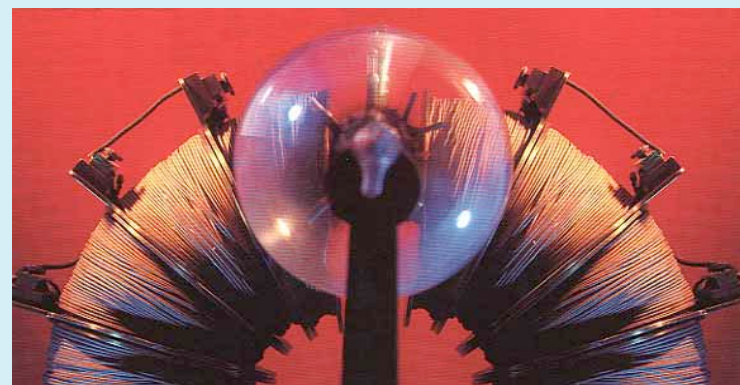
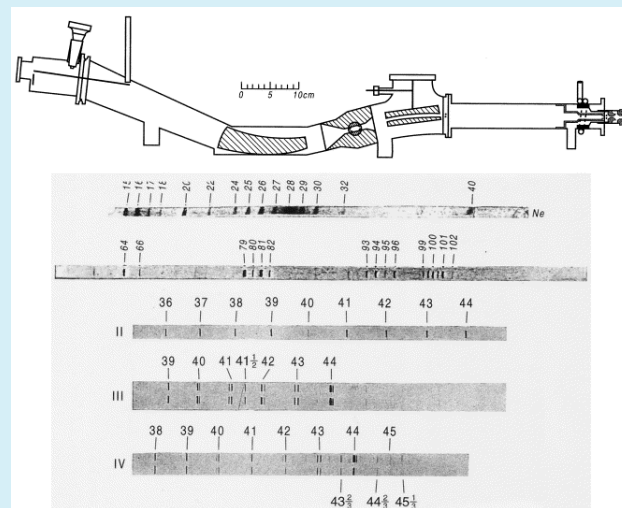

Aston's original "Positive-Ray Mass Spectrograph"

Image courtesy of [http://](http://www.ingenious.org.uk/site.asp?s=S2&DCID=1927-1085)

[www.ingenious.org.uk/site.asp?](http://www.ingenious.org.uk/site.asp?s=S2&DCID=1927-1085)

[s=S2&DCID=1927-1085](http://www.ingenious.org.uk/site.asp?s=S2&DCID=1927-1085)

Technology

Transition Workshop



Basic Components

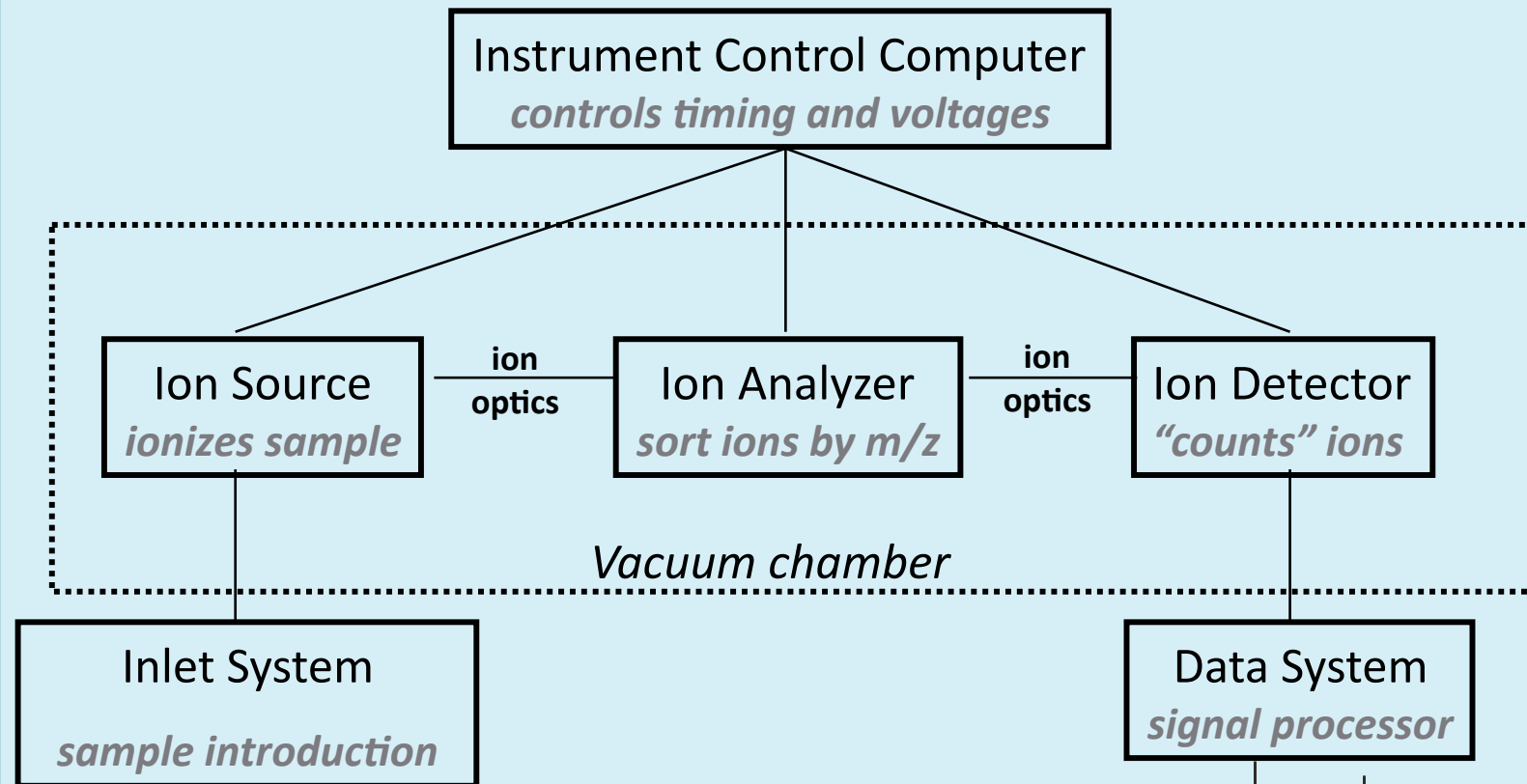

Mass Spectrum

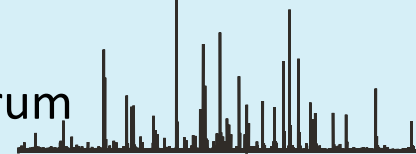

Technology
Transition Workshop



The "Mass" Spectrum

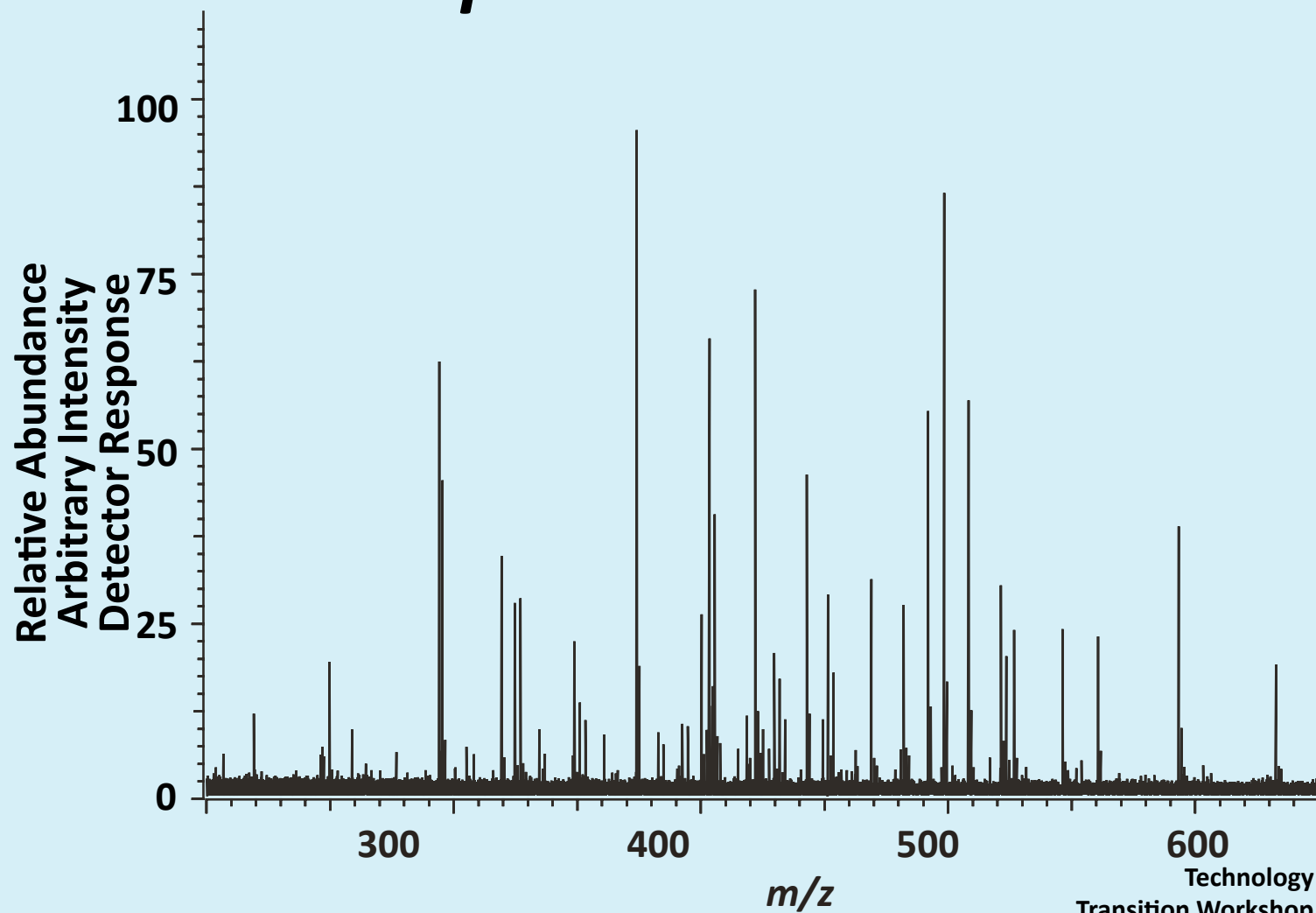

The "Mass" Spectrum

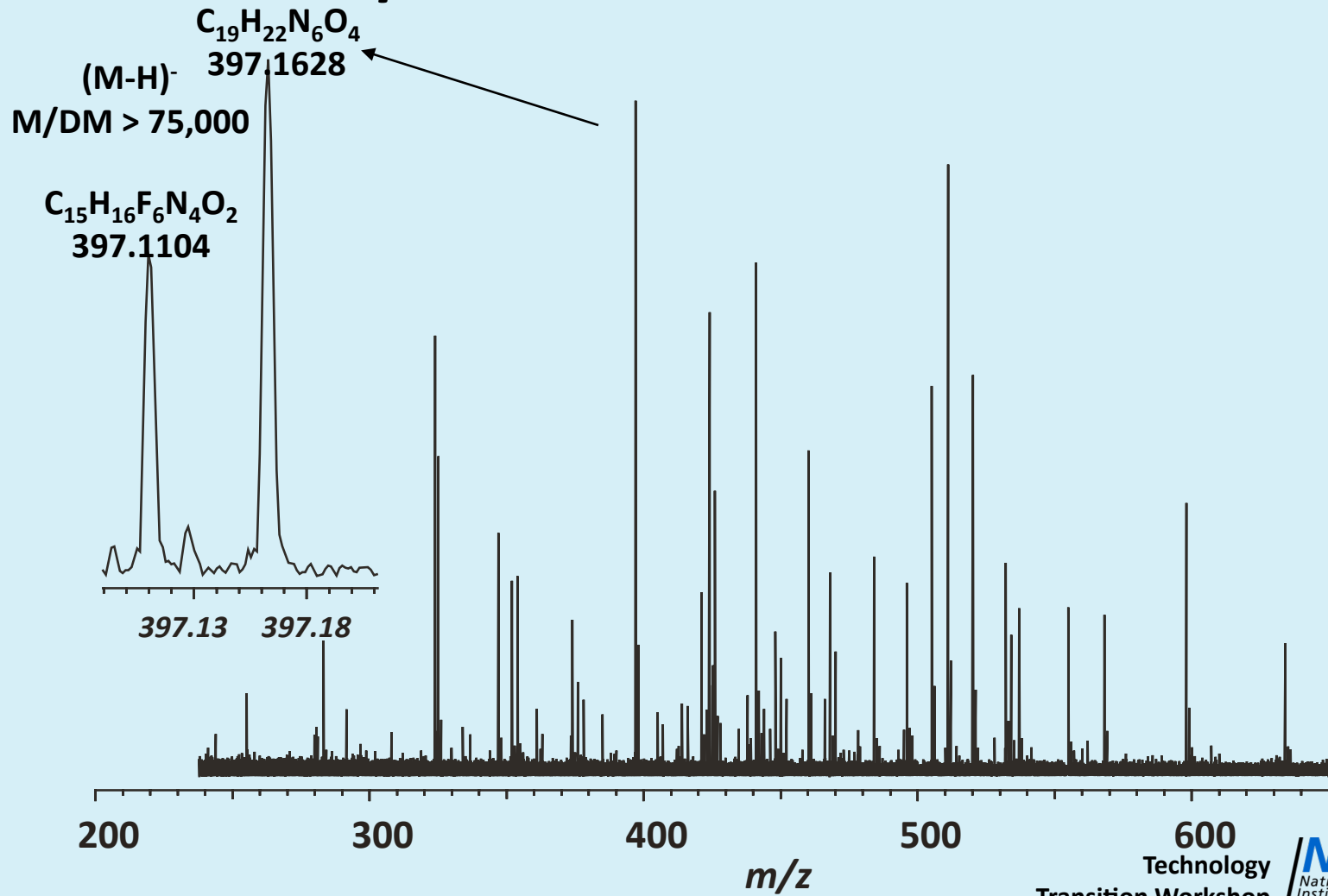

The Isotopic Envelope

- **Most elements have more than 1 isotope**
- **For a given atom type, different isotopes have different numbers of neutrons**
 - e.g., an atom of ^{12}C has 6 neutrons, 6 protons, and 6 electrons
 - an atom of ^{13}C has 7 neutrons, 6 protons, and 6 electrons
- **The mass of a neutron is 1.00867 Da**
- **Each element has different numbers and relative abundances of other isotopes:**
 - $^{12}\text{C} = 98.90\%$ $^{13}\text{C} = 1.10\%$
 - $^{35}\text{Cl} = 75.77\%$ $^{37}\text{Cl} = 24.23\%$
 - $^{19}\text{F} = 100\%$

The Isotopic Envelope

- Unless a molecule is composed of only monoisotopic elements, there is a finite probability that it will contain one or more heavy isotopes
- The relative abundance of the monoisotopic peak decreases with increasing mass
- Observed distribution is the sum of isotopic contributions from all hetero-isotopes
- Except in a few cases, “isotopic fine structure” cannot be resolved
 - e.g., for an N^{+2} peak the contributions from 2 ^{13}C and 1 ^{18}O cannot be resolved
- Consider carbon clusters:

Isotope Distributions of Carbon

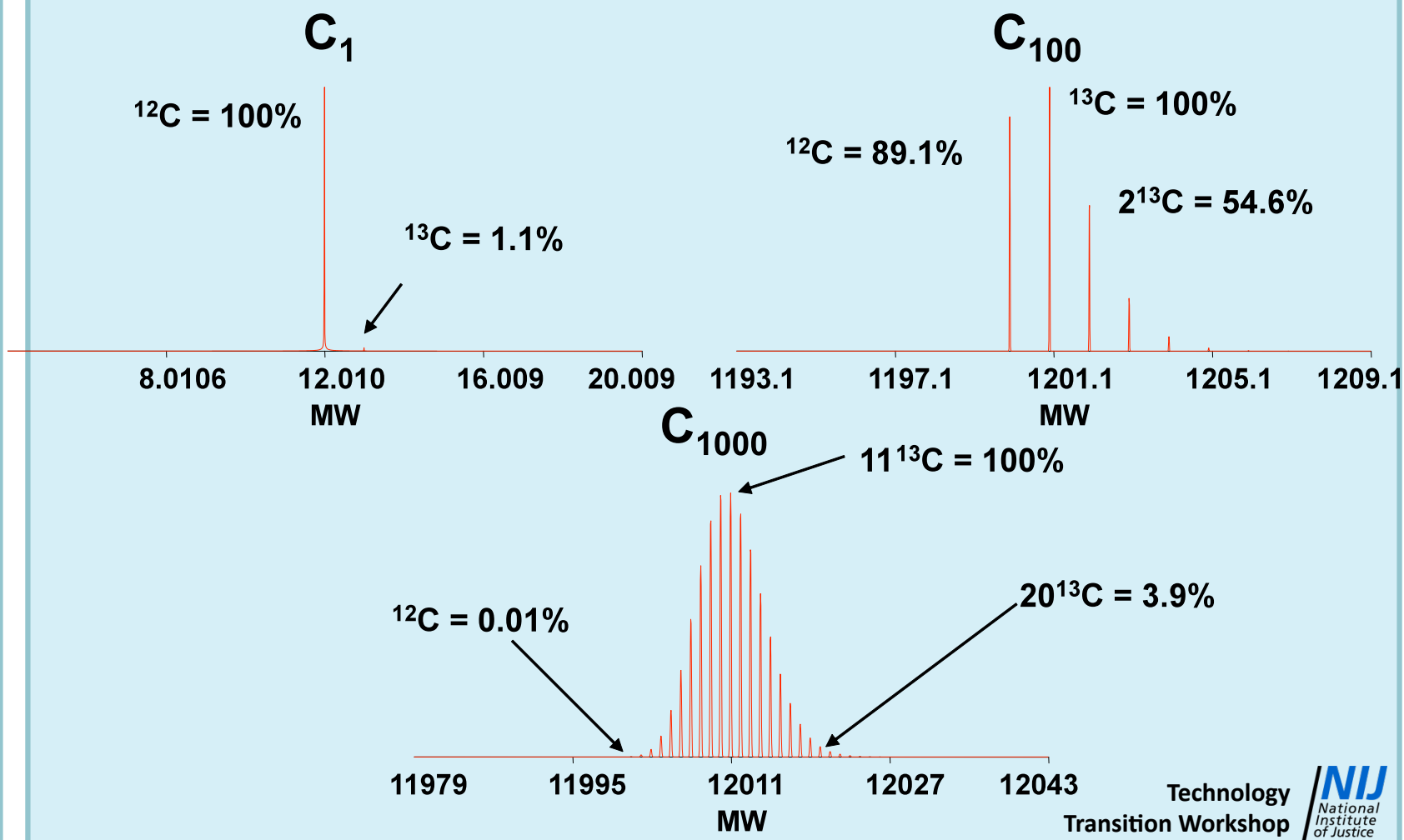

Definitions and Nomenclature

- Resolution : $M/\Delta M$
 - Actually $(m/z)/\Delta(m/z)$
 - $\Delta(m/z)$: peak width at full width half maximum (FWHM)

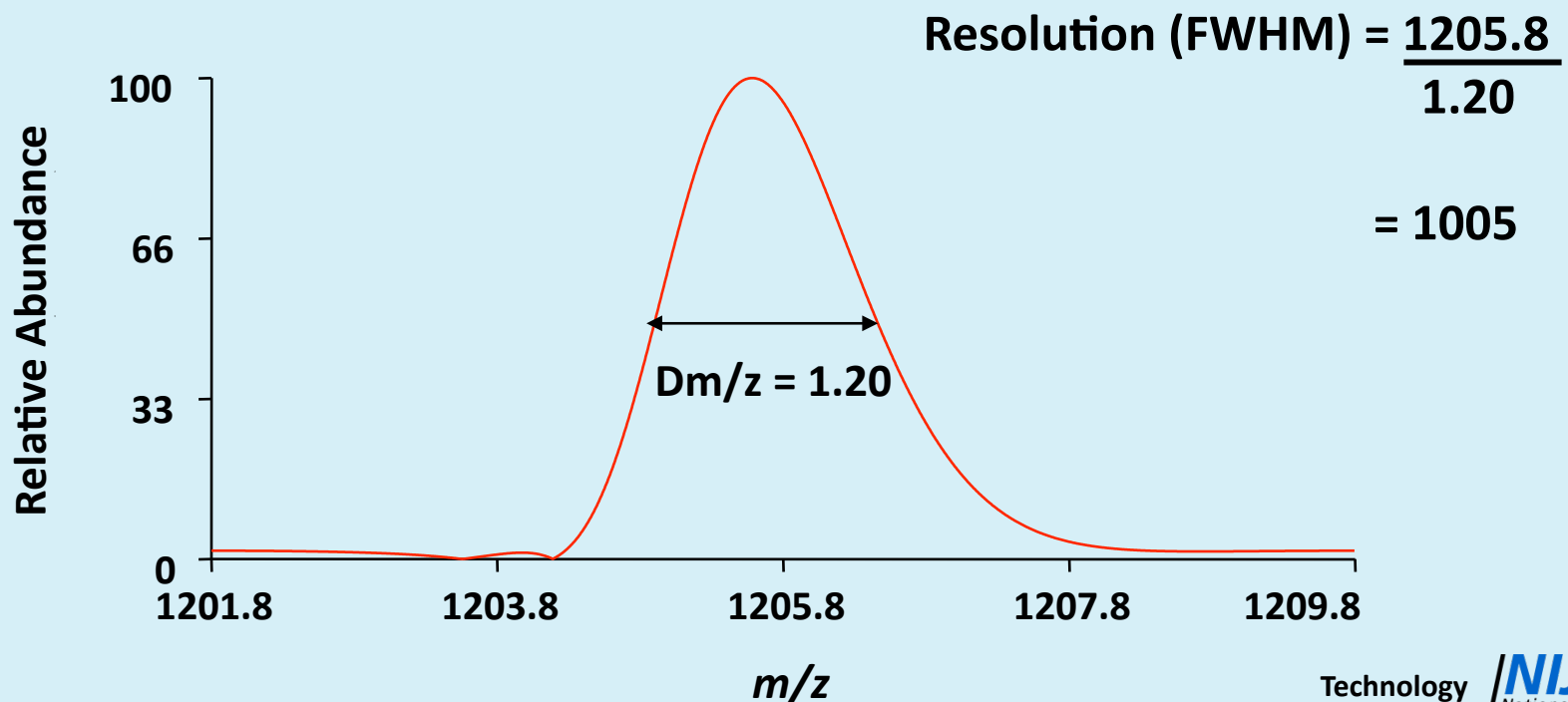

Definitions and Nomenclature

- Resolution (continued)
 - Can be limited by the inherent width of the isotope envelope
 - Step function to isotopic resolution
 - Need $M/\Delta M >$ molecular weight for isotopic resolution

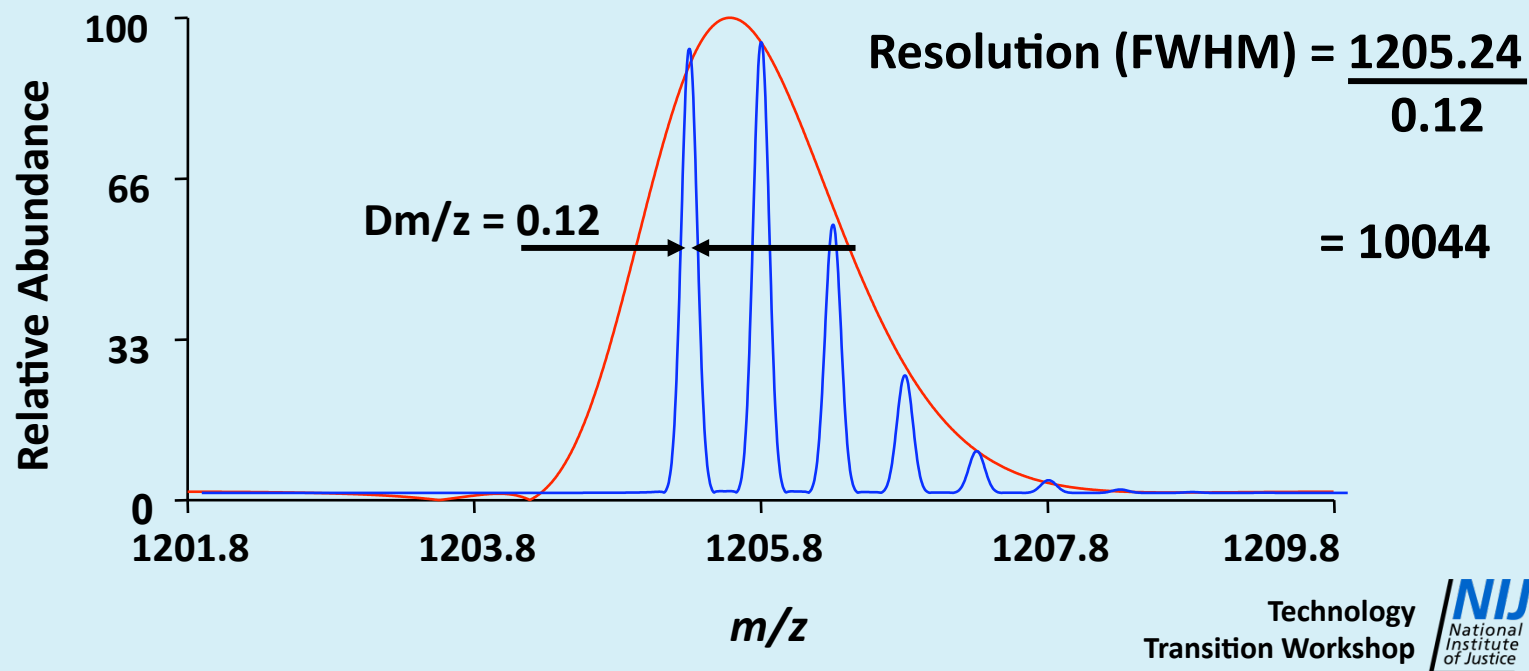

Definitions and Nomenclature: Mass Measurements

Two common ways to specify molecular weight

- **Monoisotopic Molecular Weight**
 - All ^{12}C , ^{14}N , ^{16}O , etc.
 - Most accurate method for low MW species
 - Monoisotopic peak is base peak (i.e., most abundant peak) up to about 2 kDa
- **Average Molecular Weight**
 - Most commonly used
 - Few MS platforms can resolve isotopes for analytes > 5 kDa
 - Δ between monoisotopic and average increases with increasing MW

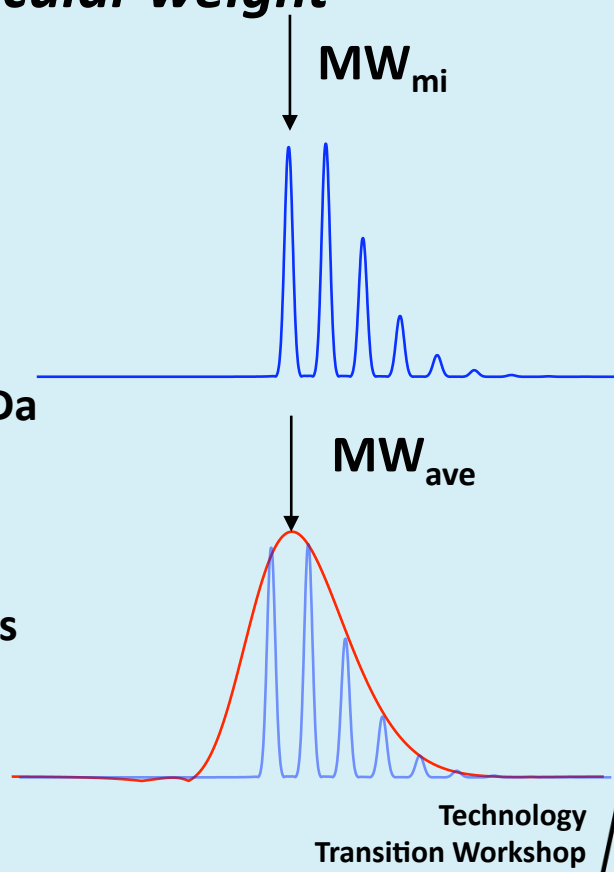

Definitions and Nomenclature

- Mass Measurement Accuracy

$$\frac{|(m/z)_{\text{theory}} - (m/z)_{\text{measured}}|}{(m/z)_{\text{theory}}} = \text{Mass Measurement Error (ppm)}$$

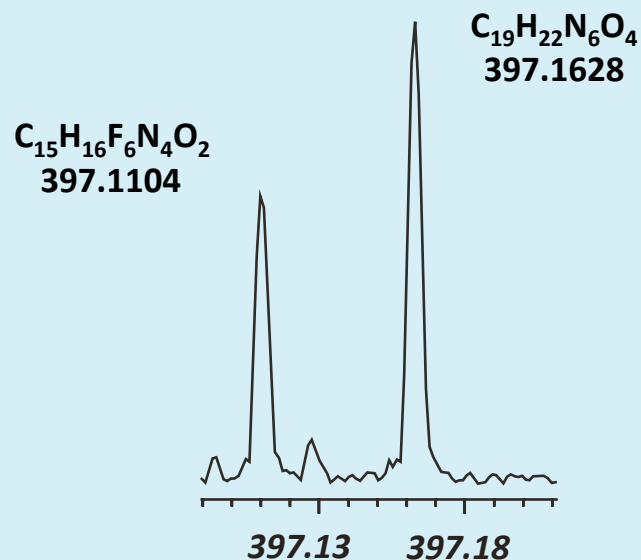

(M-H)⁻
M/DM > 75,000

cmpd	M_{calc}	M_{meas}	Dm	ppm
$C_{15}H_{16}F_6N_4O_2$	397.1105	397.1104	0.0001	0.25
$C_{19}H_{22}N_6O_4$	397.1630	397.1628	0.0002	0.50

Mass Spectrometry Nuts and Bolts

- **Ionization Sources**
- **Mass Analyzers**

Ionization Sources

- **Ionization is the process by which analytes are “charged”**
 - Adding or removing electrons (e-) (MW = 0.0006 Da)
 - Adding or removing protons (H+) (MW = 1.0078 Da)
- **Several very effective methods for ionizing low molecular weight and/or volatile compounds**
 - Limited MS to analytes with molecular weights under about 1 kDa
- **In the 1980s, two ionization methods developed for ionizing high molecular weight analytes**
 - MALDI and ESI

Ionization Sources for Low MW Analytes

- **Atmospheric Pressure Chemical Ionization (APCI)**
 - Formation of analyte ions through charge exchange with ionized carrier gas
- **Electron Ionization (EI)**
 - Generation of ions by bombarding gas phase molecules with high energy electrons
 - Analyte must be volatile
 - Ionization energy dictates extent of fragmentation
 - Still widely used w/GC

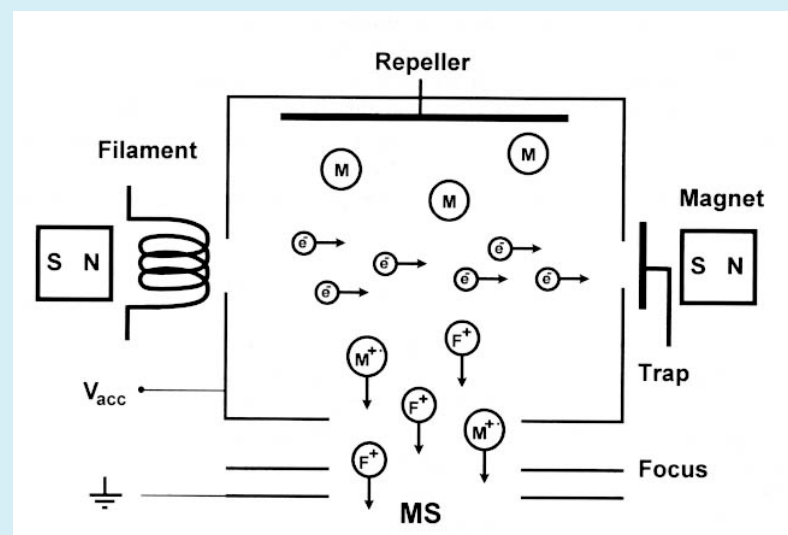

Ionization Sources – MALDI

- **Matrix Assisted Laser Desorption Ionization**
 - Sample is co-crystallized with a matrix which absorbs photons and creates a desorption plume that ionizes the sample
 - Gentle ionization technique (harsher than ESI)
 - A pulsed ion source
 - Produces singly charged ions
 - Relatively salt tolerant
 - Effective for wide range of MWs
 - Fast and automatable

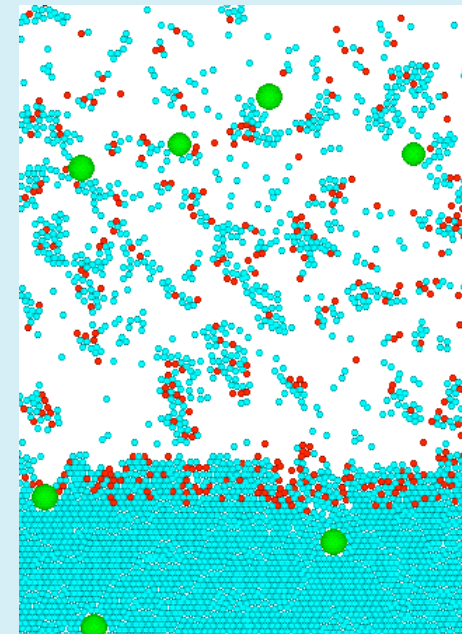
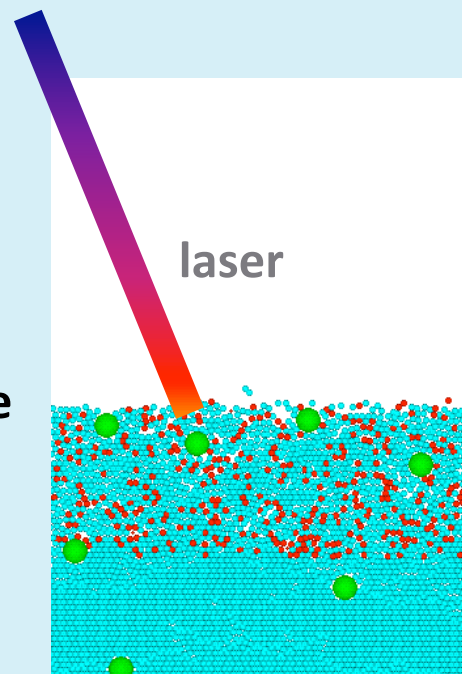

Ionization Sources - ESI

- **Electrospray Ionization**

- Ions are desolvated/desorbed from highly charged liquid droplets
- **Generates multiple charge states of large analytes**
 - Results in “folded-over” spectra which can be recorded over narrower m/z range
- **Very soft ionization technique**
 - Applicable to labile molecules and noncovalent complexes
- **Low tolerance for nonvolatile salts, buffer additives, and detergents**
 - Rigorous sample clean-up required for some applications
- **High sensitivity**
 - Applicable to analyte concentrations as low as 1 nM

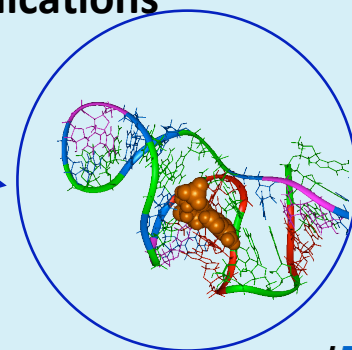
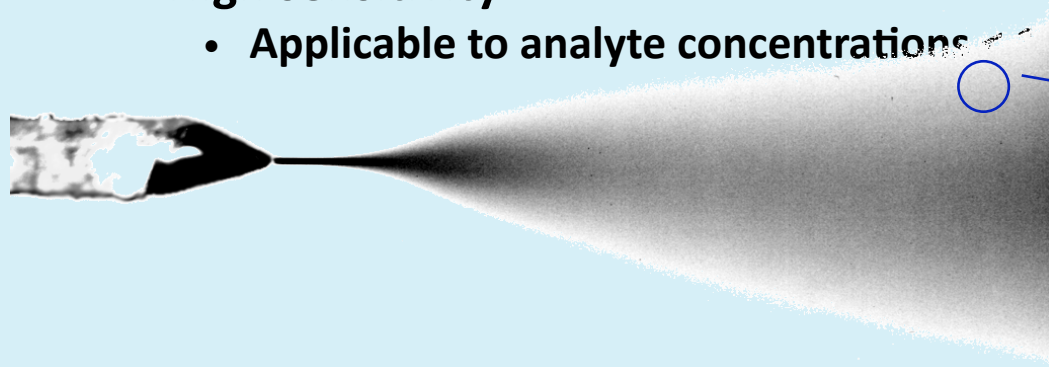

Technology
Transition Workshop



A Negative Ionization Mode ESI Mass Spectrum of a Low MW Analyte: Singly Charged Spectrum

$(M-H^+)^{1-}$

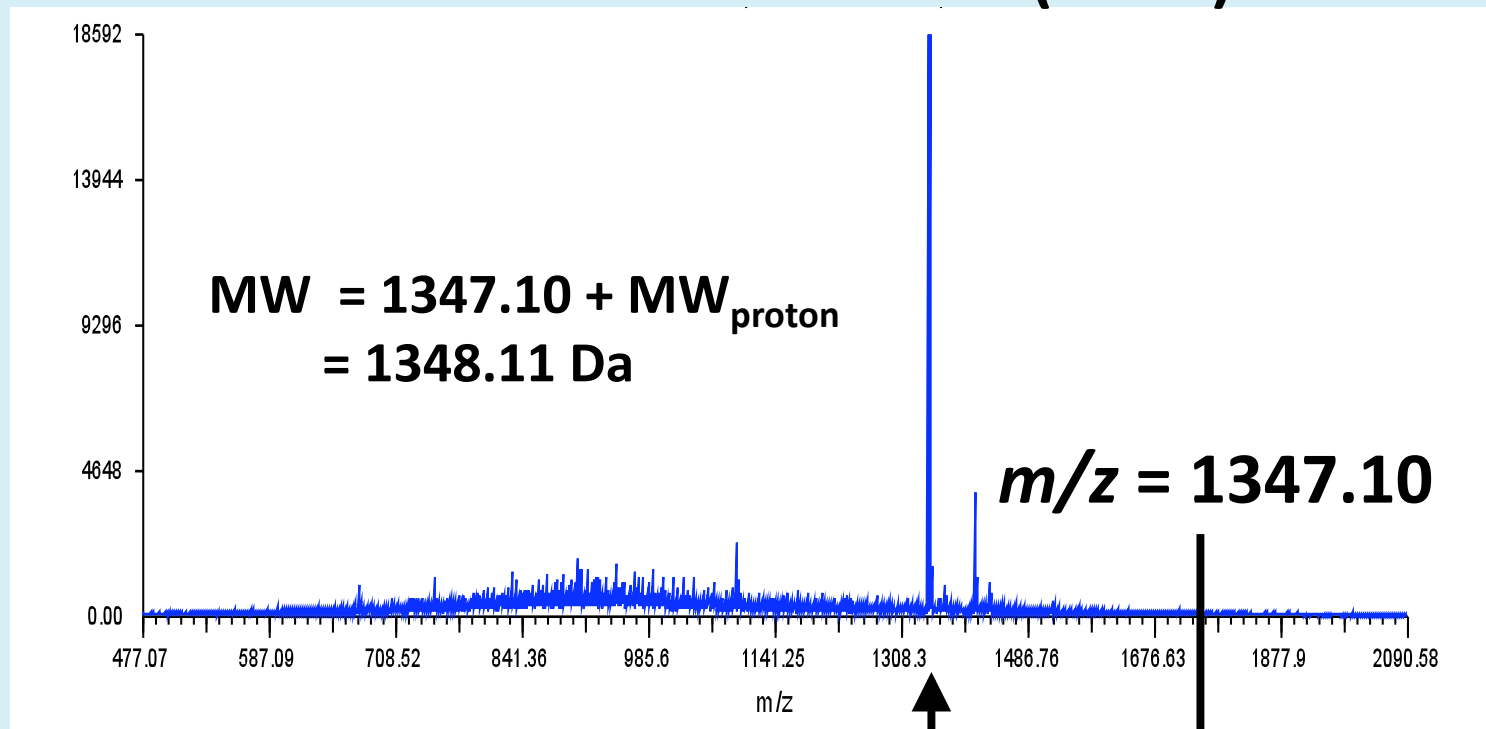

Technology
Transition Workshop



An ESI (+) Mass Spectrum of a High MW Analyte (Carbonic Anhydrase Protein MW = 28,821 Da)

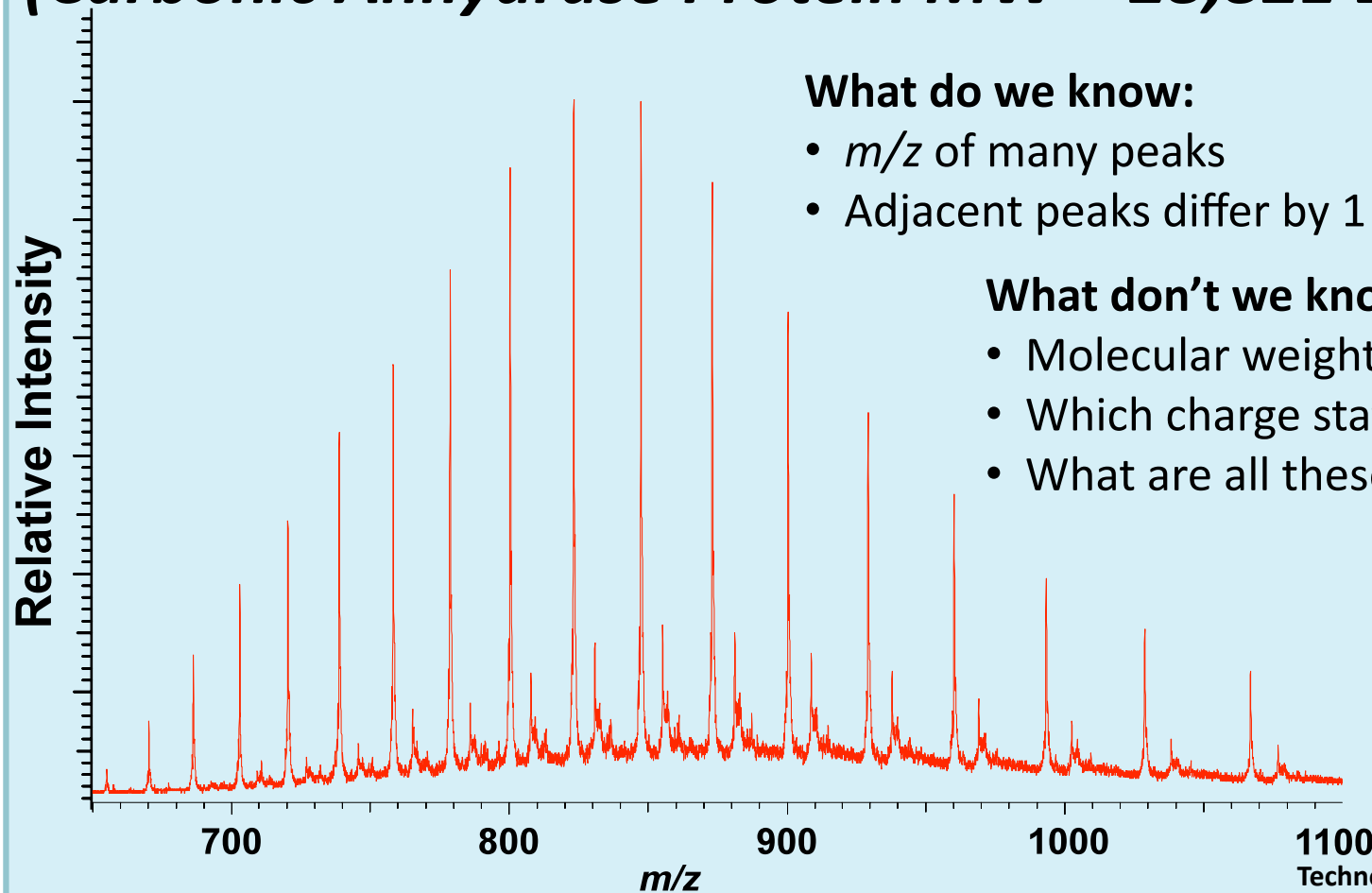

What do we know:

- m/z of many peaks
- Adjacent peaks differ by 1 charge

What don't we know:

- Molecular weight?
- Which charge states?
- What are all these peaks?

Conventional “Deconvolution” of ESI-MS Spectrum

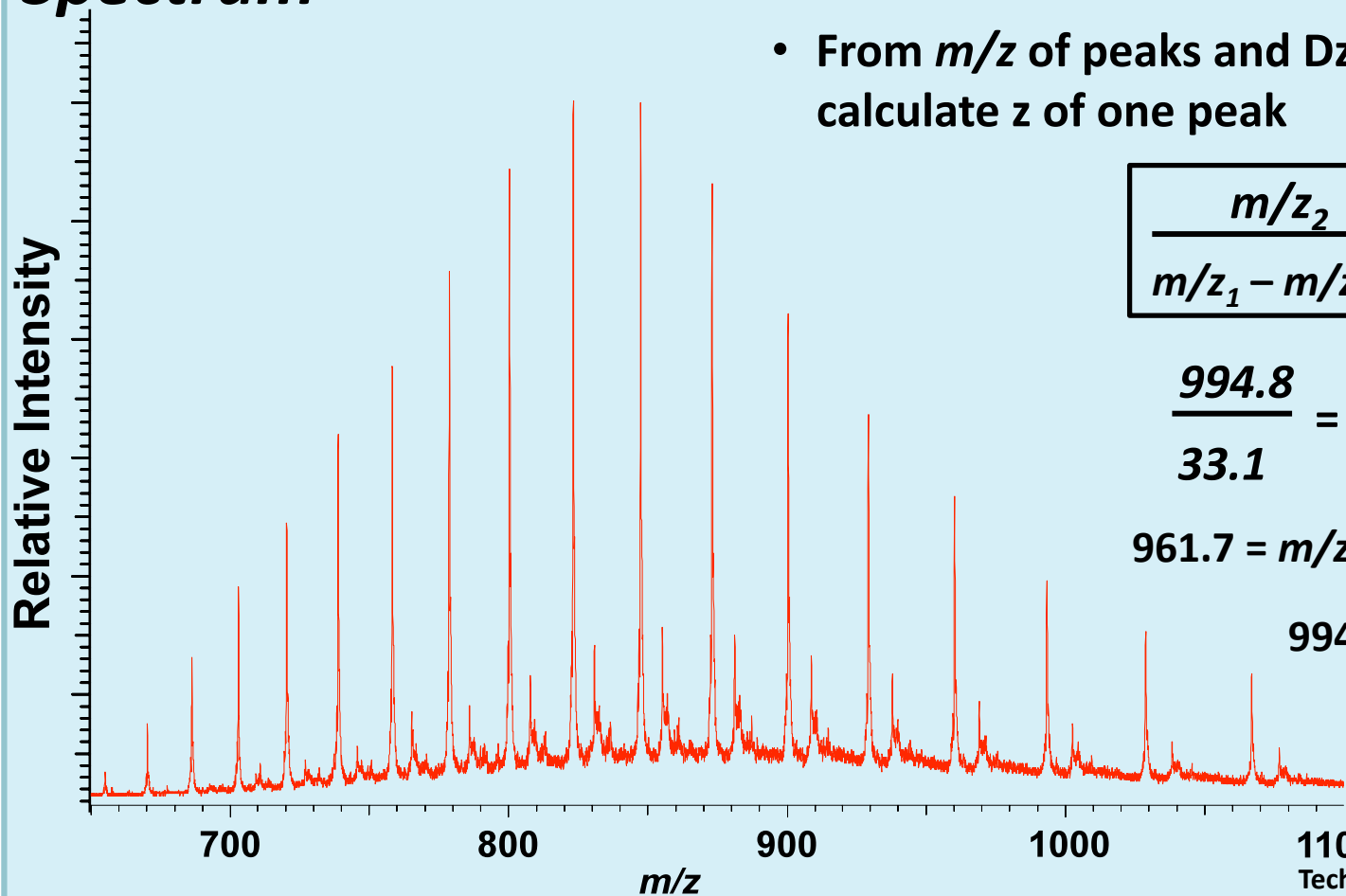

- From m/z of peaks and Δz , calculate z of one peak

$$\frac{m/z_2}{m/z_1 - m/z_2} = z_1$$

$$\frac{994.8}{33.1} = 30 = z_1$$

$$961.7 = m/z_1$$

$$994.8 = m/z_2$$

Conventional “Deconvolution” of ESI-MS Spectrum

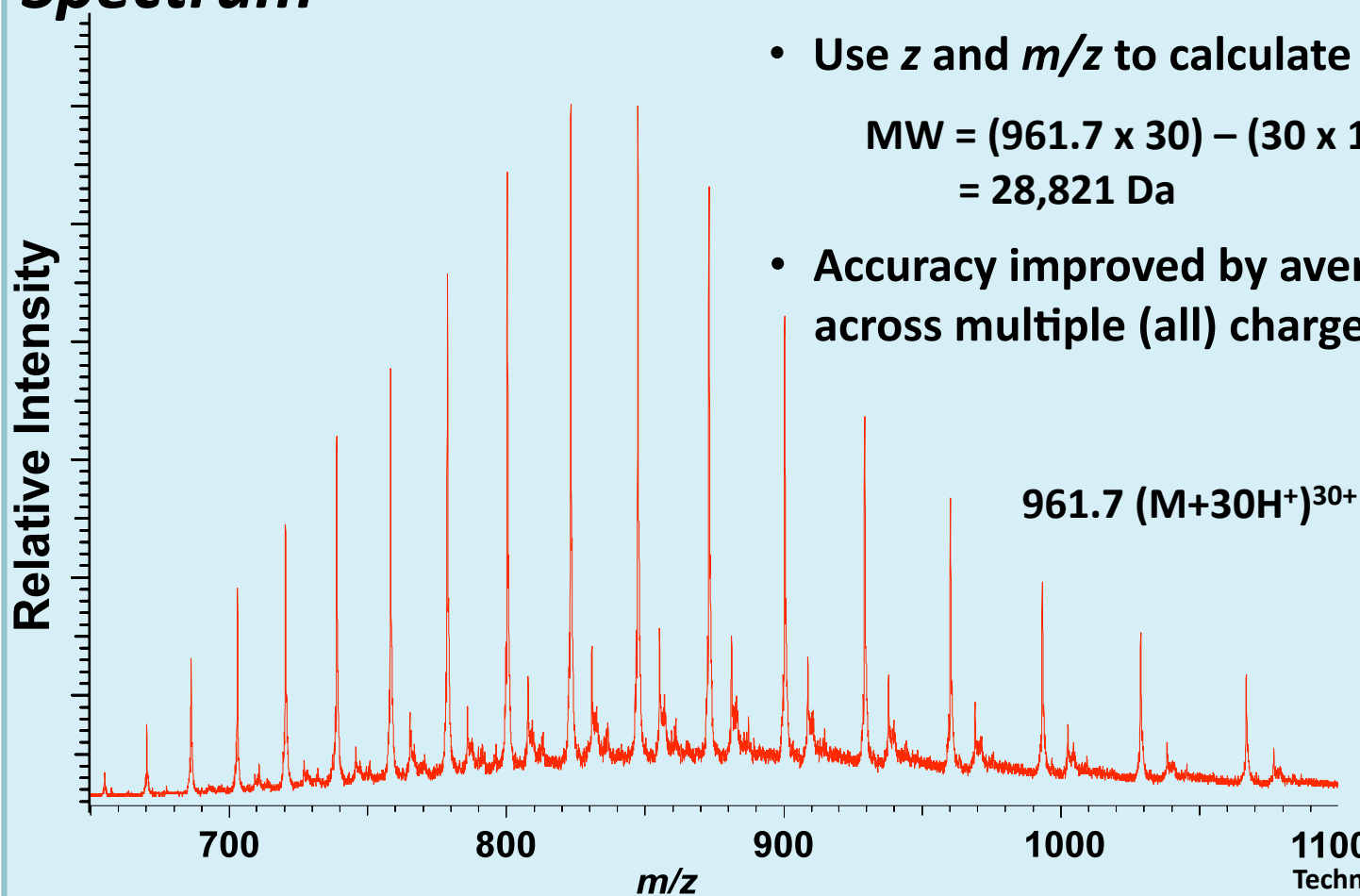

- Use z and m/z to calculate mass
$$MW = (961.7 \times 30) - (30 \times 1.0078)$$
$$= 28,821 \text{ Da}$$
- Accuracy improved by averaging across multiple (all) charge states

ESI-MS of DNA

- Phosphodiester backbone is easily deprotonated at high pH
- ESI most effective in negative mode (in positive ionization mode basic groups on bases are protonated)
- Both backbone and nucleobase linkages to sugar are relatively labile
- We have optimized solution and interface conditions for DNA analysis by mass spectrometry over the past 10 years

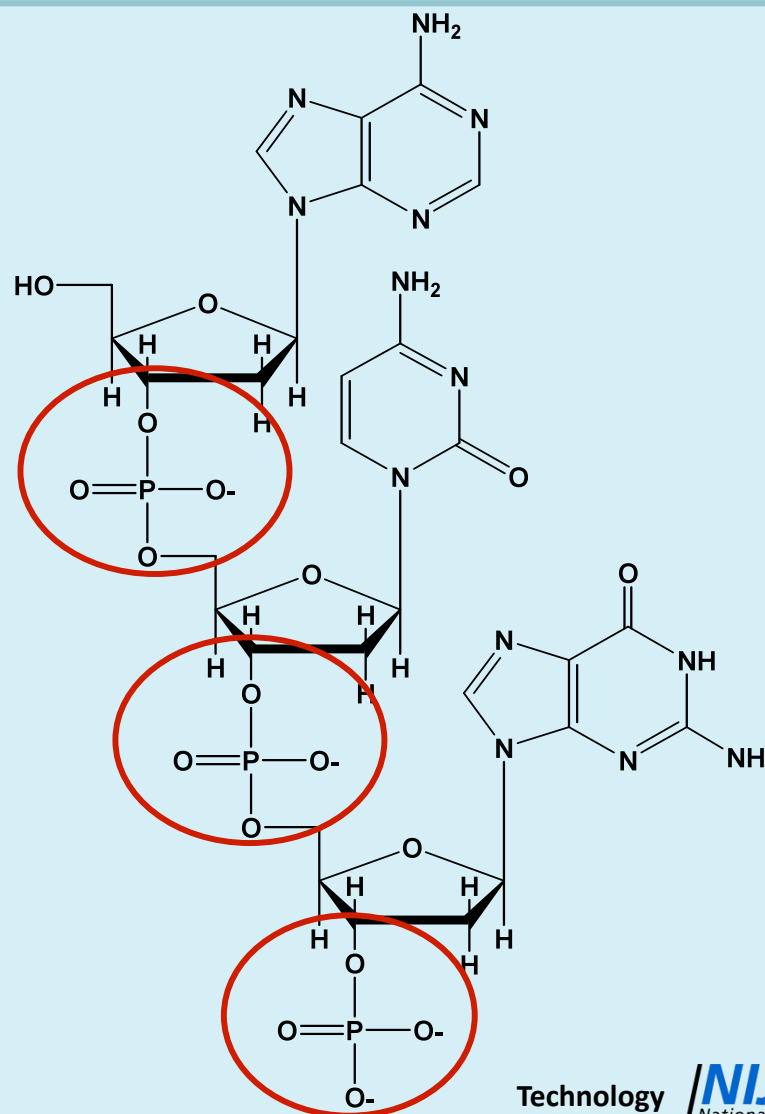

Then and Now

- Then (1981)
 - Pre-contributions of Fenn, Tanaka, Hillenkamp/Karas
 - 20-mer DNA
 - Cf²⁵² desorption – TOF
 - $M/\Delta M$ about 25
 - $MW = 6301 \pm 5$
 - About 800 ppm

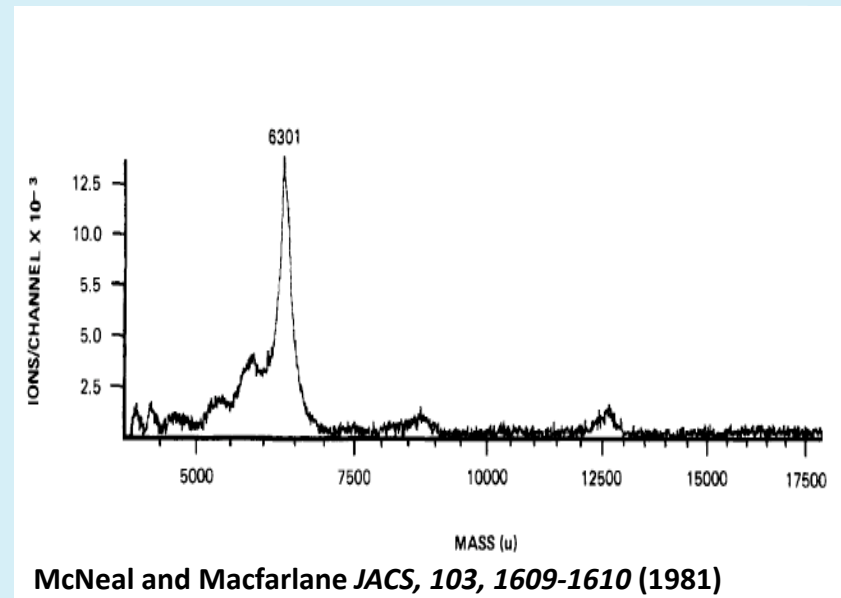

Then and Now

- **Now**

- Additional contributions from Marshall, McLafferty, McLuckey, Smith and others
- 120-mer DNA acquired in fully automated modality
- ESI-FTICR
- $M/\Delta M = 150,000$
- $MW = 37,091.18 \pm 0.04$
 - About 1 ppm

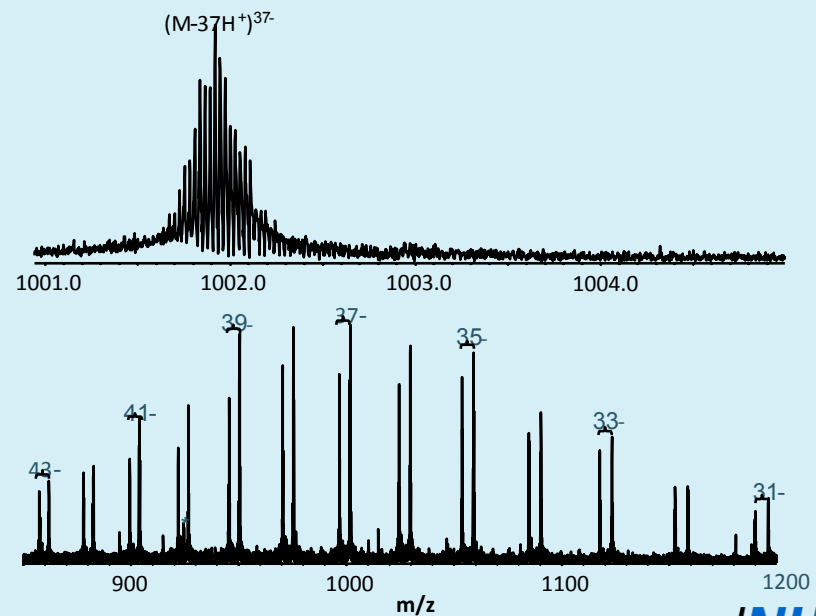

Technology
Transition Workshop



An ESI Mass Spectrum of a PCR Product

- Doublet peaks at each charge state correspond to forward and reverse strands of amplicon

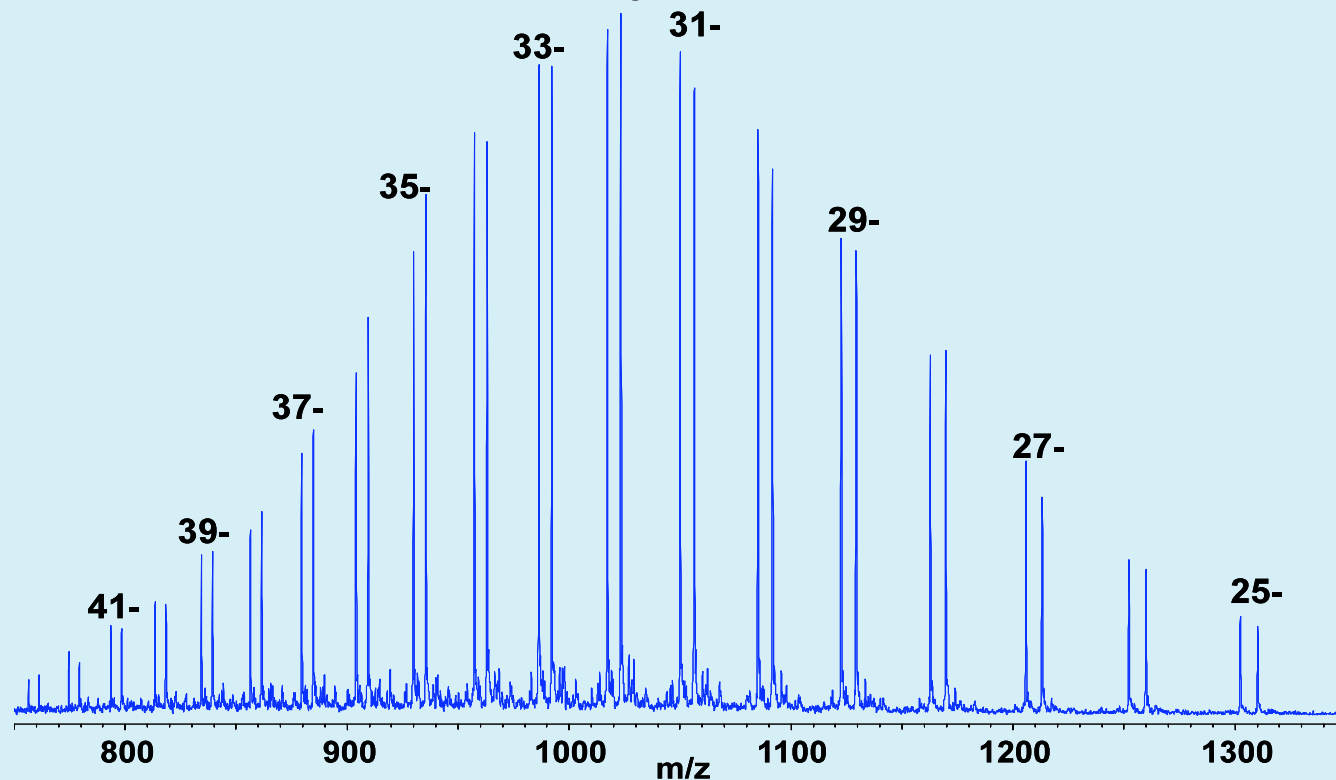

“Raw” ESI-MS Spectrum from 3-plex PCR Mix

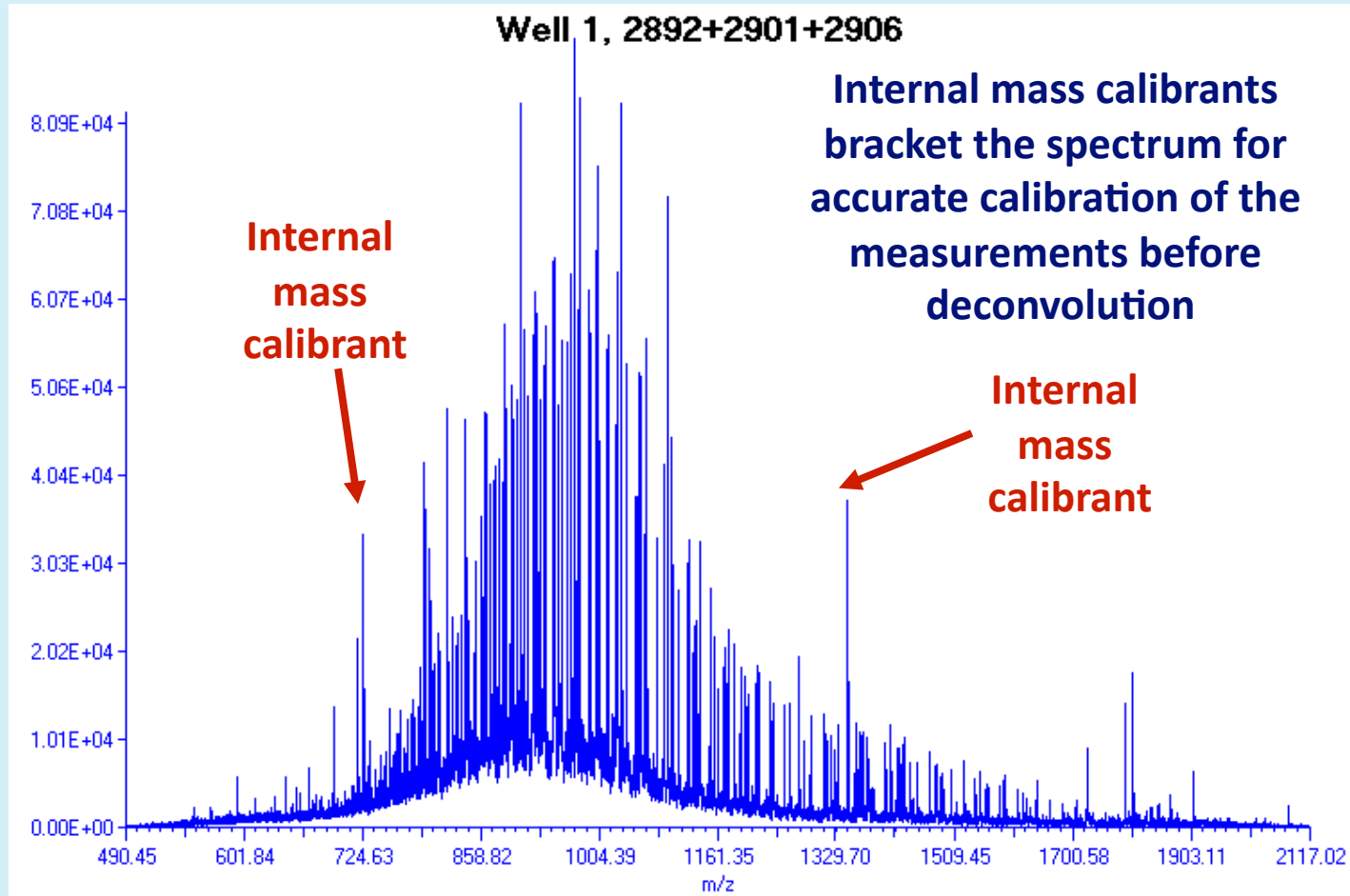

Deconvolved ESI-MS spectrum from 3-plex PCR

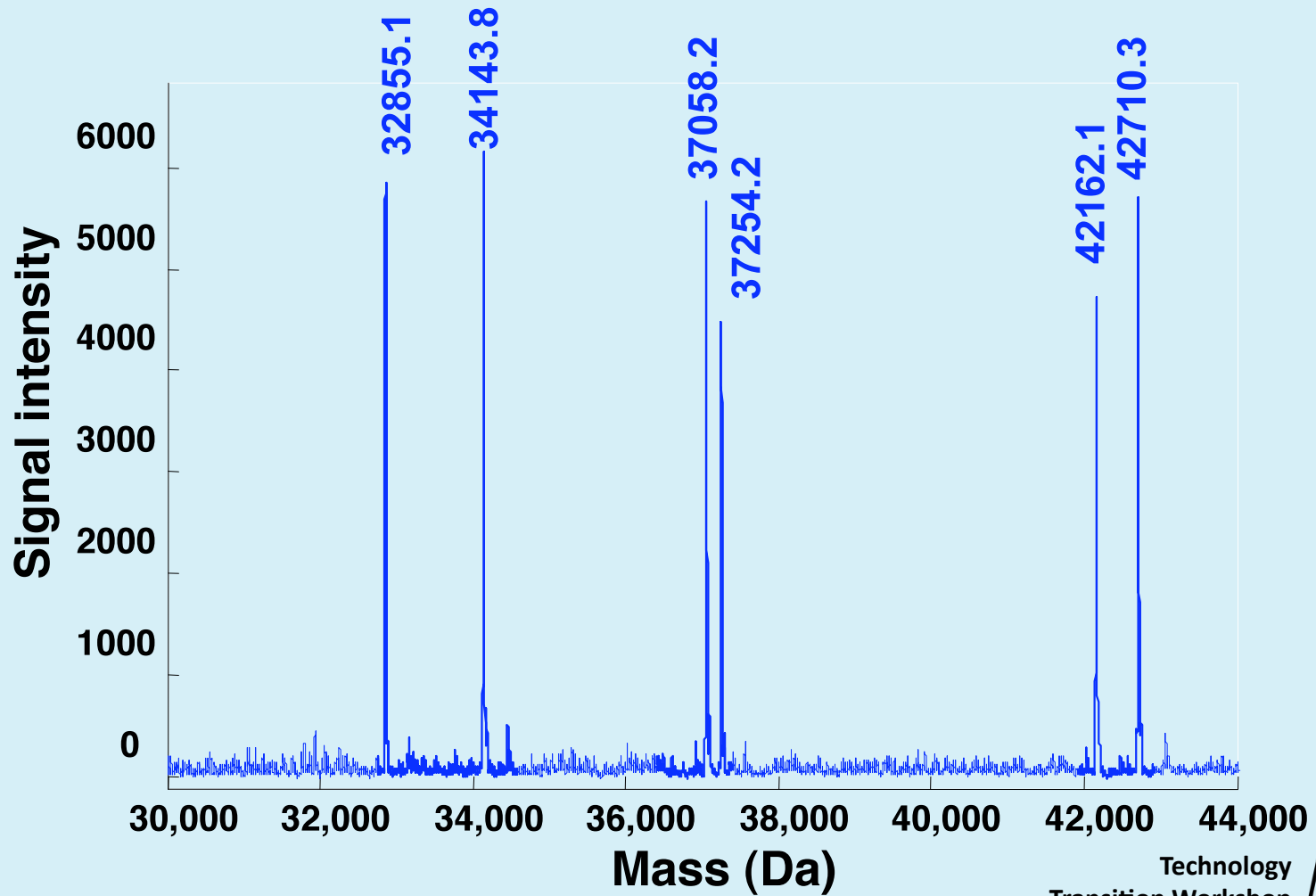

Masses to Base Composition



© Microsoft
Penny = 2.500 g
Nickel = 3.950 g
Dime = 2.268 g
Quarter = 5.670 g



Scale

Weight = 4.6 grams
∴ 2 dimes

© Microsoft

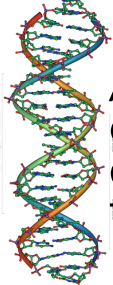

A = 313.0576 amu
G = 329.0526 amu
C = 289.0464 amu
T = 304.0461 amu

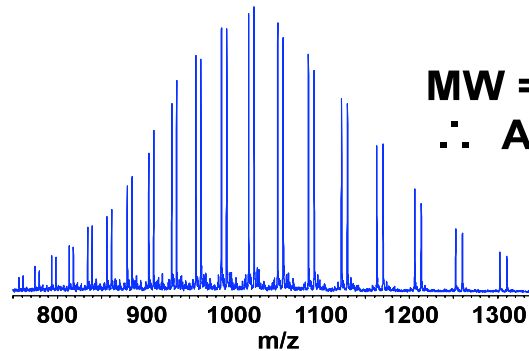

Mass spectrum

MW = 32,588.90 amu
∴ A28 G29 C25 T24

Requires 25 ppm
mass measurement error

Math takes into account
Watson-Crick base pairing

Technology
Transition Workshop



Masses to Base Composition

- **Require masses of both strands and fact that the strands are complimentary to determine base composition**

Single Strand: 32889.450 Da

(± 25 ppm or 0.75 Da): 928 base comps

(± 1 ppm or 0.03 Da): 82 base comps

Single Strand: 33071.462 Da

(± 25 ppm or 0.75 Da): 948 base comps

(± 1 ppm or 0.03 Da): 95 base comps

Da: Dalton (atomic mass unit)

ppm: part per million

Exact Mass Measurements of Both Strands Facilitate Unambiguous Base Composition Determination

ppm	# comp pairs
0-25	1
50	13
100	66
250	378
500	1447

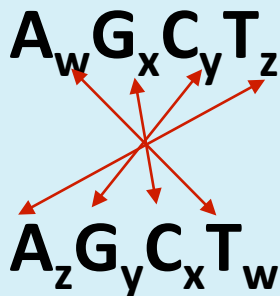

DNA Single Strand | RNA Single Strand | PNA Single Strand | DNA Double Strand

Sense MW: 32889.4500 Error (ppm): 25.00
 Anti-sense MW: 33071.4600 Error (ppm): 25.00

Constraints

Forward primer composition Reverse primer composition

Result count: 2 Monoisotopic **Calculate**

Display from: 1 to: 2 **Prev** **Next** **Save**

Count	A	G	C	T	Length	Mass	Error
1	27	25	30	25	107	32889.4546	0.14
2	25	30	25	27	107	33071.4622	0.07

Odd numbers: sense strand. Even: complementary anti-sense strand.

Technology
Transition Workshop

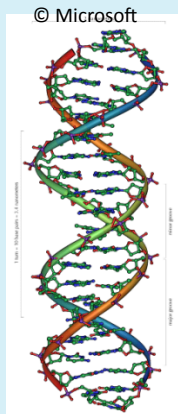

Image courtesy of Ibis™ staff

Mass Measurement and the “Canadian Nickel”



Penny = 2.500 g
Nickel* = 3.950 g
Dime = 2.268 g
Quarter = 5.670 g



A = 313.0576 amu
G = 329.0526 amu
C = 289.0464 amu
T = 304.0461 amu

- The “Coins and Scale” analogy doesn’t work if using all US coins as a US nickel weighs 5.000 g
 - Thus 5 g could be two pennies or one nickel
- Interesting parallel to nucleobases with mass measurement error
 - A mass shift of 15 ± 1 Da could be a $A \Rightarrow G$ or a $C \Rightarrow T$
 - A double SNP $A \Rightarrow G$ and $T \Rightarrow C$ would result in a 1 Dalton difference
 - A one Dalton uncertainty is consistent with two base compositions

Mass Measurement and the “Canadian Nickel”



Penny = 2.500 g
Nickel* = 3.950 g
Dime = 2.268 g
Quarter = 5.670 g

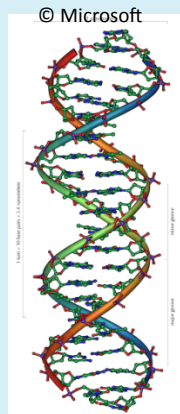

A = 313.0576 amu
G = 339.1662 amu
C = 289.0464 amu
T = 304.0461 amu

- The “Coins and Scale” analogy doesn’t work if using all US coins as a US nickel weighs 5.000 g
 - Thus 5 g could be two pennies or one nickel
- Interesting parallel to nucleobases with mass measurement error
 - A mass shift of 15 ± 1 Da could be a A \rightarrow G or a C \rightarrow T
 - A double SNP A \rightarrow G and T \rightarrow C would result in a 1 Dalton difference
 - A one Dalton uncertainty is consistent with two base compositions
- We have a “Canadian Nickel” nucleobase
 - ^{13}C labeled guanosine shifts the mass by 10 Da per incorporation
 - No confusion over which SNP is present
 - No uncertainty as to whether the A/G T/C double SNP is present

High Mass Precision and Mass Tag Combine to Provide Unambiguous Base Compositions in Routine Operation

Some double SNPs cause small mass differences

Without mass tag:

Product strands differ by 1 Da for two products that differ by a G→A and C→T SNP at the same time.

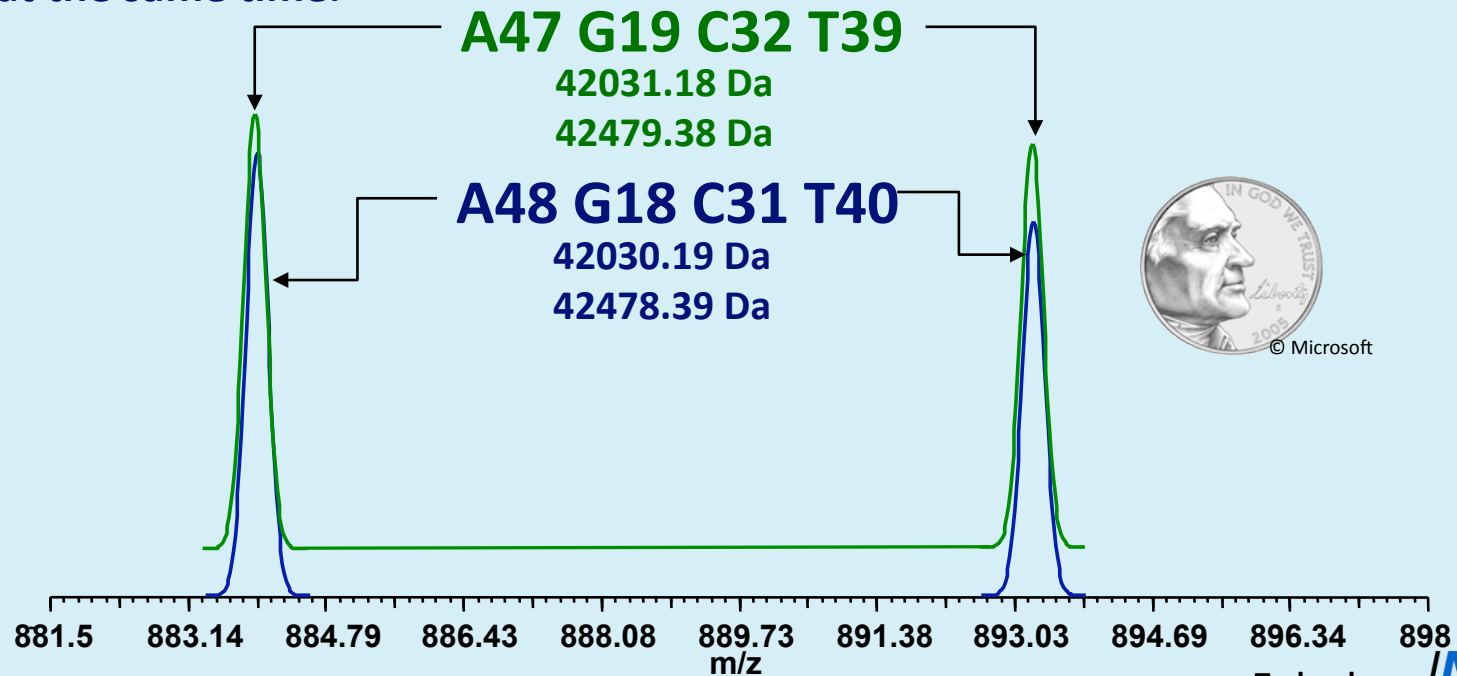

Technology
Transition Workshop

Mass Tag Increases Mass Separation for These SNPs

With mass tag:

With ^{13}C -dGTP, the mass separation increases to ~ 10 Da for each strand

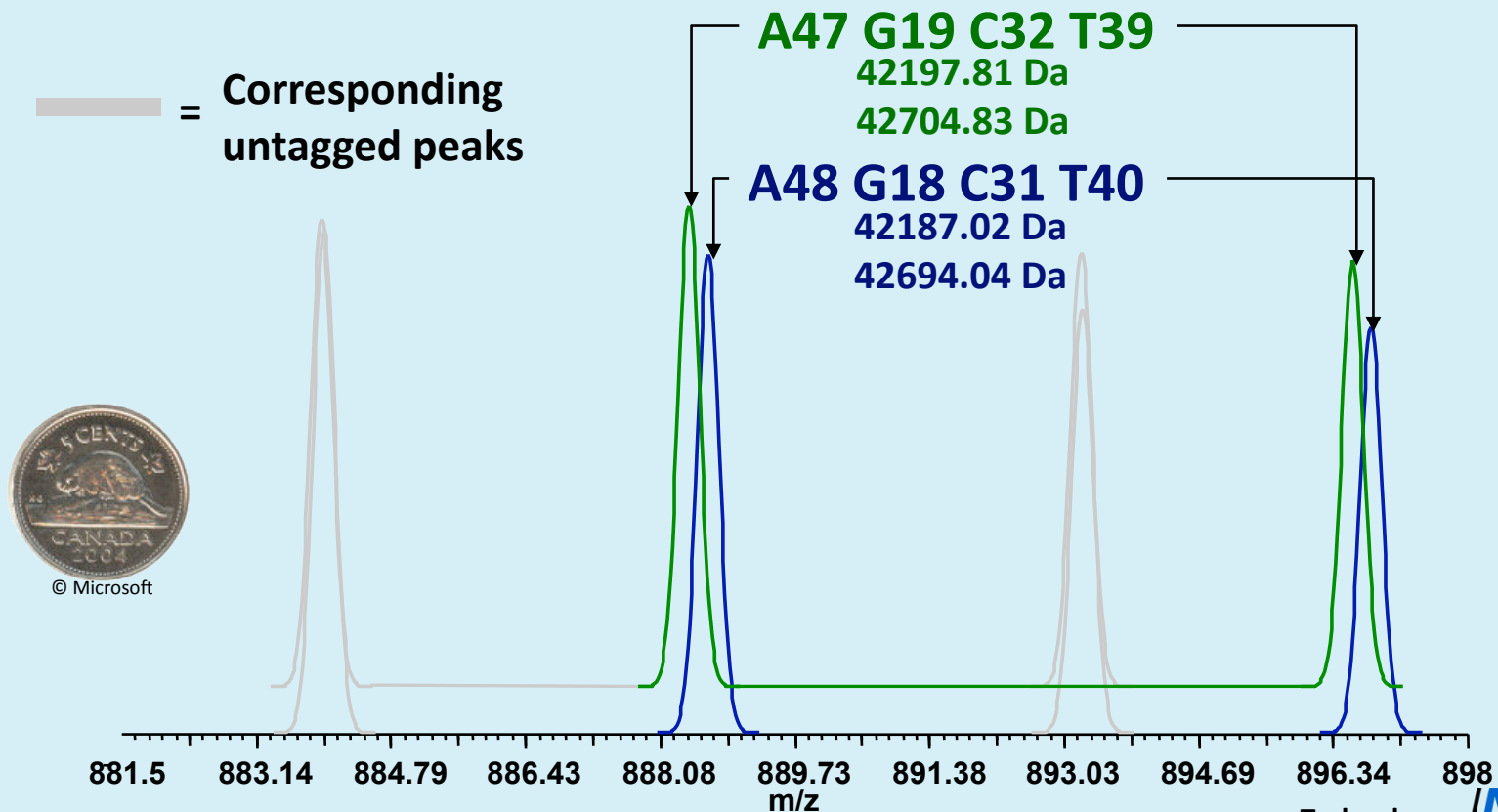

Technology
Transition Workshop

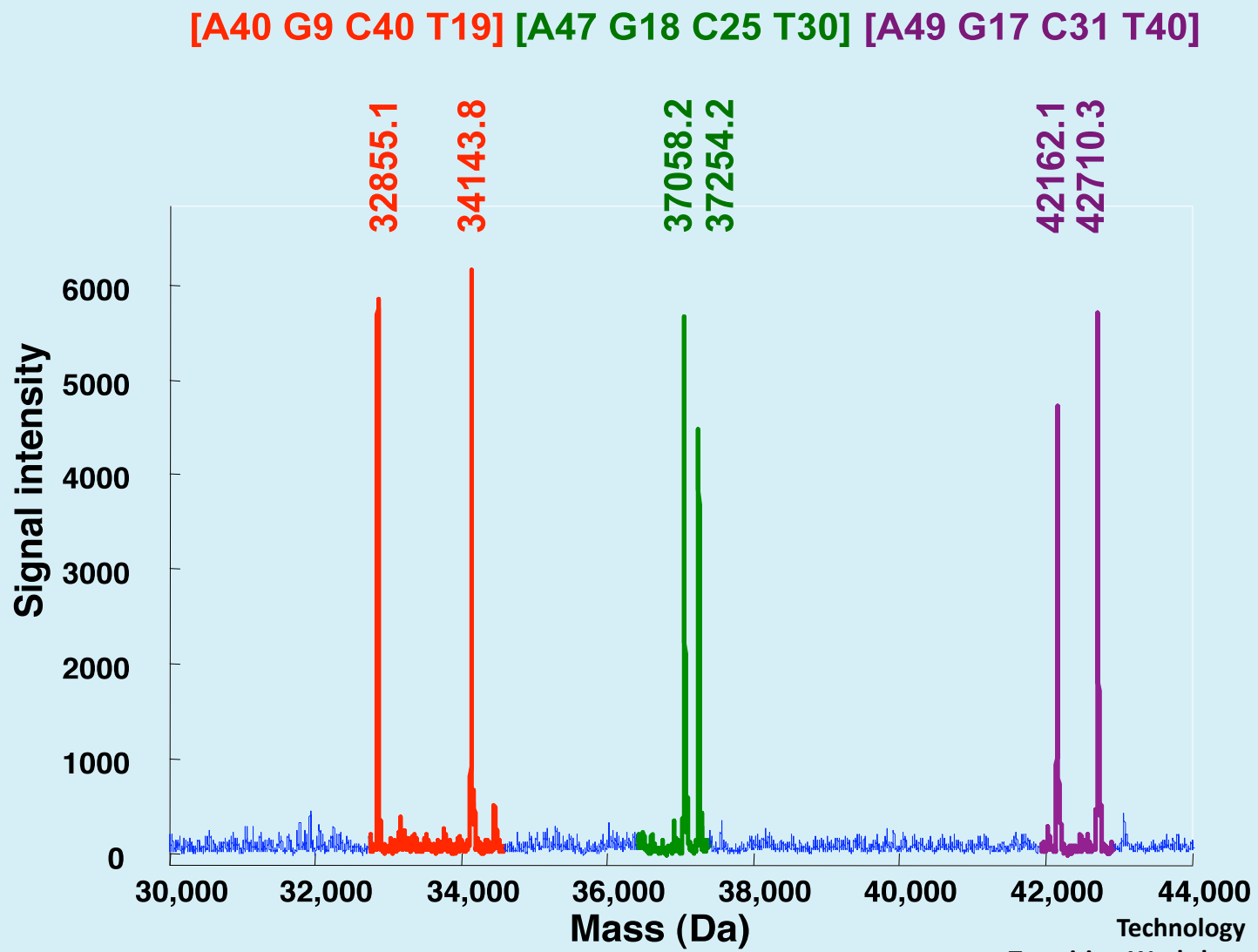

Size Constraints

- We generally characterize PCR products ≤ 150 bp (~47 kDa/strand)
- In general, 25 ppm mass measurement error or better will provide unambiguous *de novo* base composition for double stranded products ≤ 150 bp
- Analysis of larger products is feasible, but information content is lower
 - Spectra more “congested”
 - Math not in our favor

299 bp PCR Product on ESI-TOF (well 9/24)

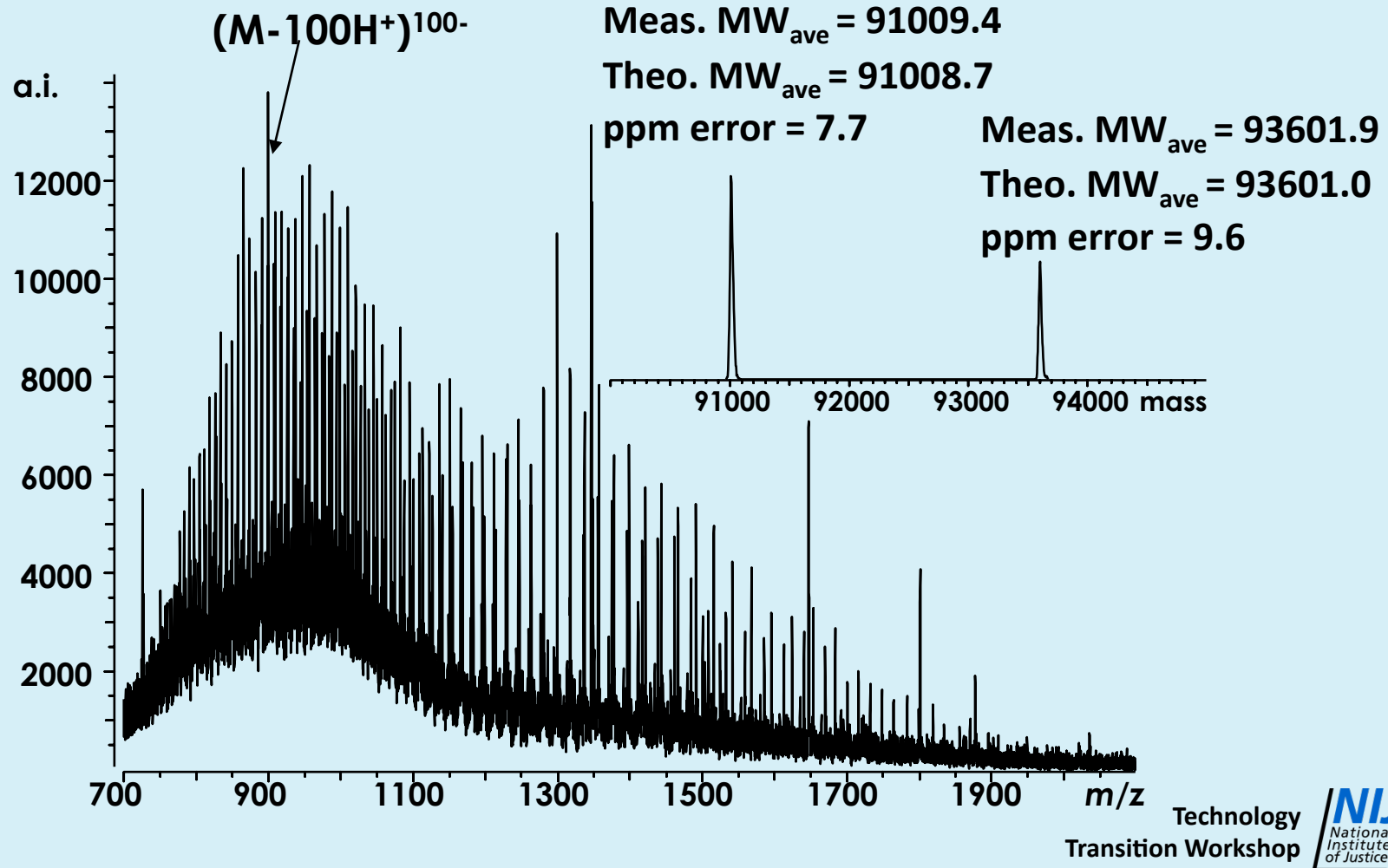

Number of Possible Base Compositions as a Function of ppm Mass Error and Mass

ppm Error	SS1	SS2	DS
	MW _{ave} = 91008.7	MW _{ave} = 93601.0	
1	2563	2580	1
5	12846	14296	3
10	25809	29054	10
20 *	x	x	62
25	x	x	89
50	x	x	367

***Average ESI-TOF error over 24 replicates of 299-mer**

ESI Parameters

- Ion desolvation is controlled by several parameters
 - Temperature of desolvation gas
 - Capillary-skimmer potential difference
 - Pressure in capillary-skimmer interface region
- Excessive activation in the interface region can lead to dissociation
 - DNA is labile relative to proteins and one must use “gentle” interface conditions

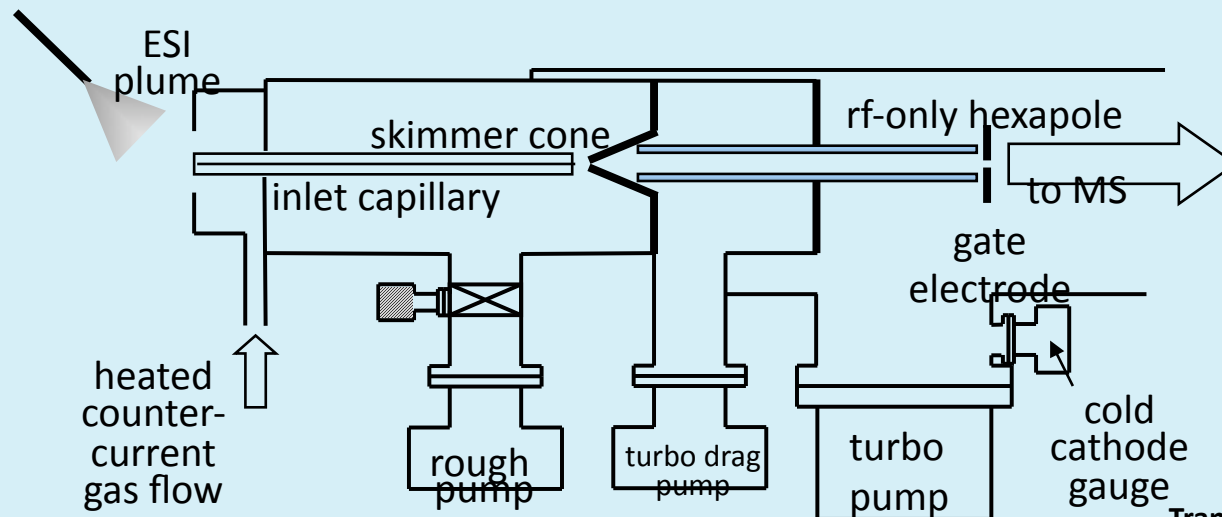

Salt is a Killer

- **Nonvolatile counterions (e.g., Na⁺, K⁺, Mg²⁺) are not removed during desolvation**
 - High concentrations can preclude the generation of a stable ESI plume
- **Oligonucleotides are more vulnerable to contamination than proteins**
 - Phosphodiester backbone is highly anionic
 - Larger oligonucleotides more salt intolerant than smaller ones
- **Effects of salt can be partially mitigated by choice of buffers**
 - See Griffey et al. RCMS 9, (1995) 97-102

Salt is a Killer

ESI-MS of 20-mer phosphorothioate oligonucleotide

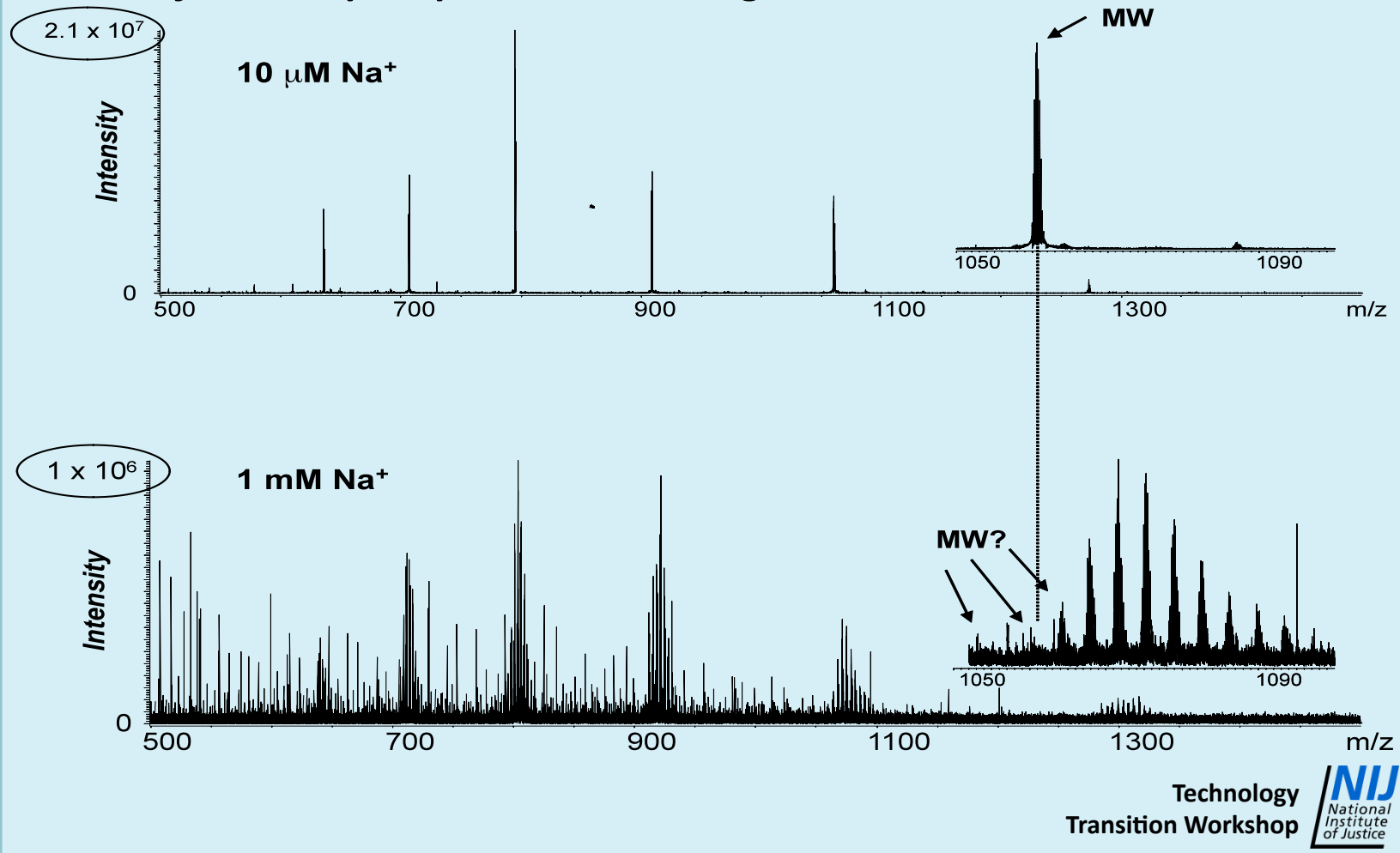

Comparison of Raw Data for Adducted vs. Non-Adducted Mass Spectrum

Adducted

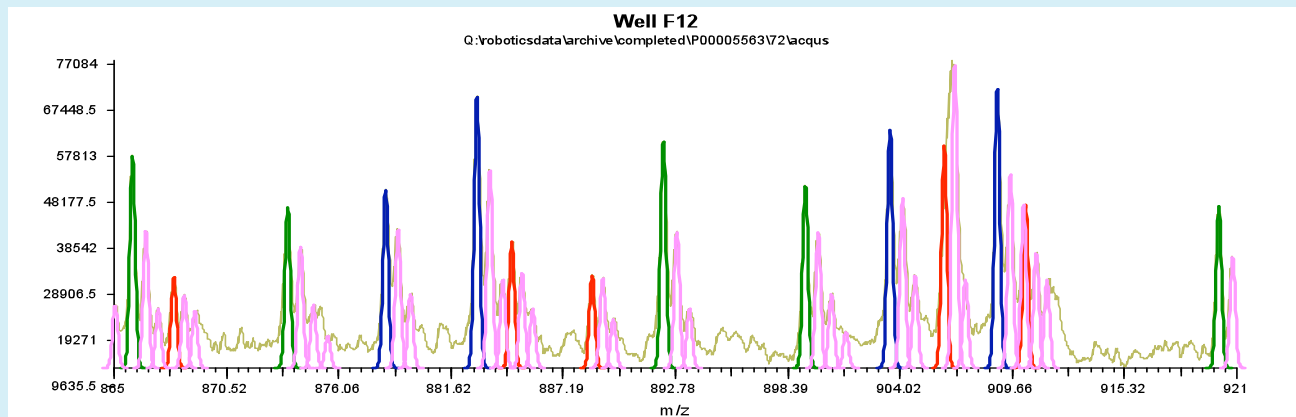

Not adducted

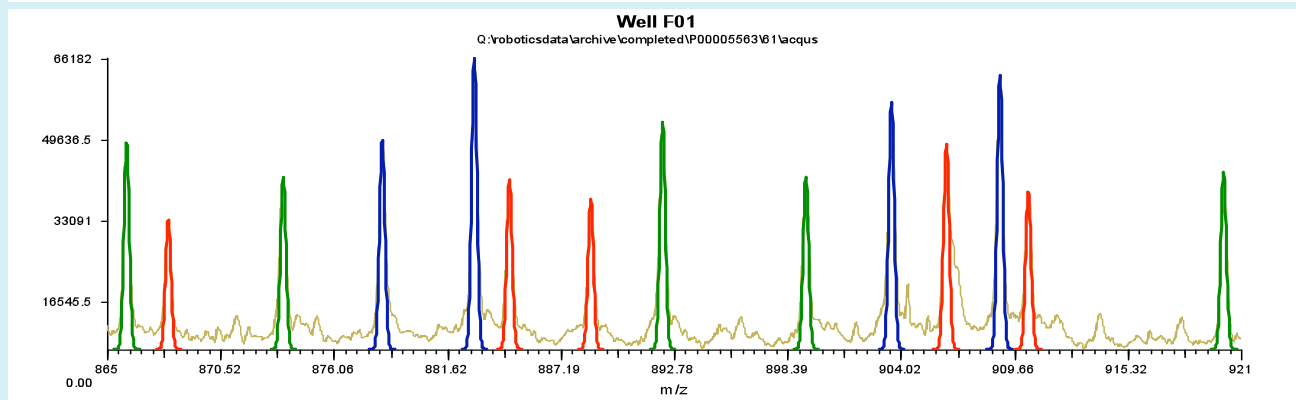

Mass Analyzers

- All work by measuring the response of charged particles to electric and/or magnetic fields
- All work at reduced pressure to reduce ion-neutral collisions
 - Want to minimize scatter and/or neutralization
 - Typical operating pressures
 - linear quadrupoles $\sim 5 \times 10^{-5}$ torr
 - FTICR $< 10^{-9}$ torr
 - TOF 10^{-5} to 10^{-7} torr

Highlights of TOF-MS

Advantages

- **Simple and rugged benchtop construction**
- **Theoretically unlimited mass range**
- **Adaptable to many ionization sources**
- **Fast acquisition – signal averaging to improve S/N**
- **Mass accuracy rivals that of FTICR**

Highlights of TOF-MS

Disadvantages

- **Limited resolution**
 - Theoretically limited to detection electronics
 - Practically limited by energy and spatial spreads in ions
- **TOF is inherently pulsed**
 - Must wait for longest flight time ions before sending next packet of ions (Hz to kHz typical repetition rates)
 - Cannot simultaneously measure all m/z values
 - This is mitigated by external ion accumulation

Time-of-flight (TOF) Mass Analyzers

- Ions are accelerated by electric field (V/d)
- Ions then drift at their final velocity for a fixed distance
- Ions impact a detector and their flight time is recorded
 - Flight time is :
 - Proportional to velocity
 - Proportional to the square root of m/z,

$$K.E. = \frac{1}{2}mv^2 \Rightarrow \frac{1}{2}\left(\frac{m}{z}\right)v^2 = \vec{V} / d$$

where v is velocity, V/d is field strength

$$t = L/v = L\sqrt{m/2zV}$$

t: sec L: meters v: velocity m: kg z: Coulombs V: volts
lower *m/z* ions reach higher velocity than higher *m/z* ions

TOF-MS Detection Schemes

- “Particle impact, electron generation, and detection”
 - Electron multiplier
 - Microchannel plate
 - Hybrids or other particle detectors
- Simplest example: metal foil

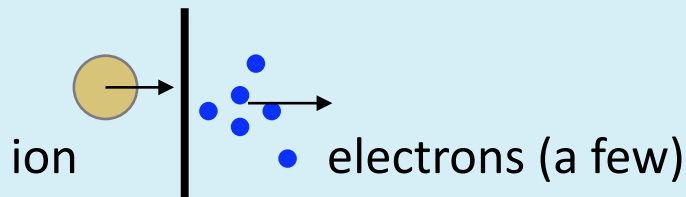

- Most common: microchannel plate
 - Array of tilted glass channels
 - 2 to 10 microns
 - Electron cascade = gain
 - Also used in night vision

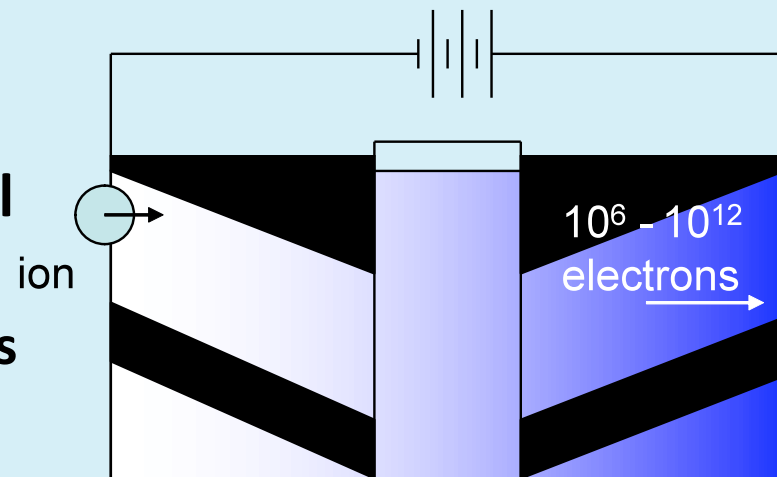

Mass Analyzers – TOF

- Linear geometry
 - Ions drift in field-free region, but energy spread ($+\Delta E$) leads to time spread ($-\Delta T$) (more energy gives shorter TOF)

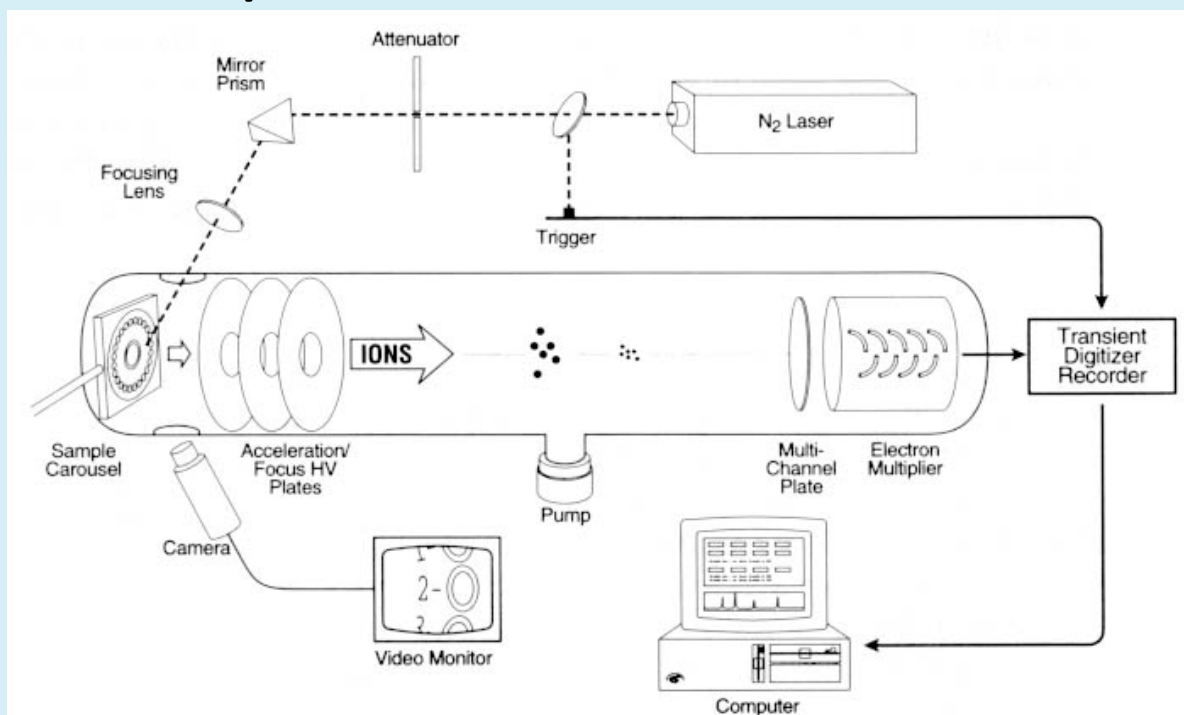

Mass Analyzers – TOF

- **Reflectron**

- Ions drift, but at ion mirror they turn around
- $+\Delta E$ (energy spread) leads to deeper penetration in ion mirror
- Linear config: $+\Delta E$ leads to $-\Delta T$
- Reflectron config: $+\Delta E$ leads to $-\Delta T + \Delta T (= 0)$; energy spread eliminated at detector

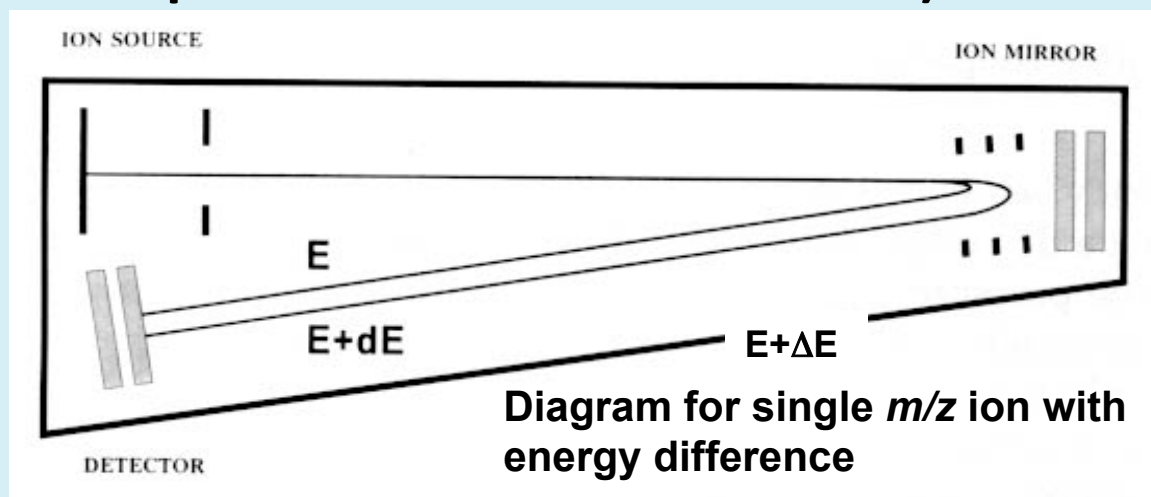

Mass Spectrometry and PLEX-ID™

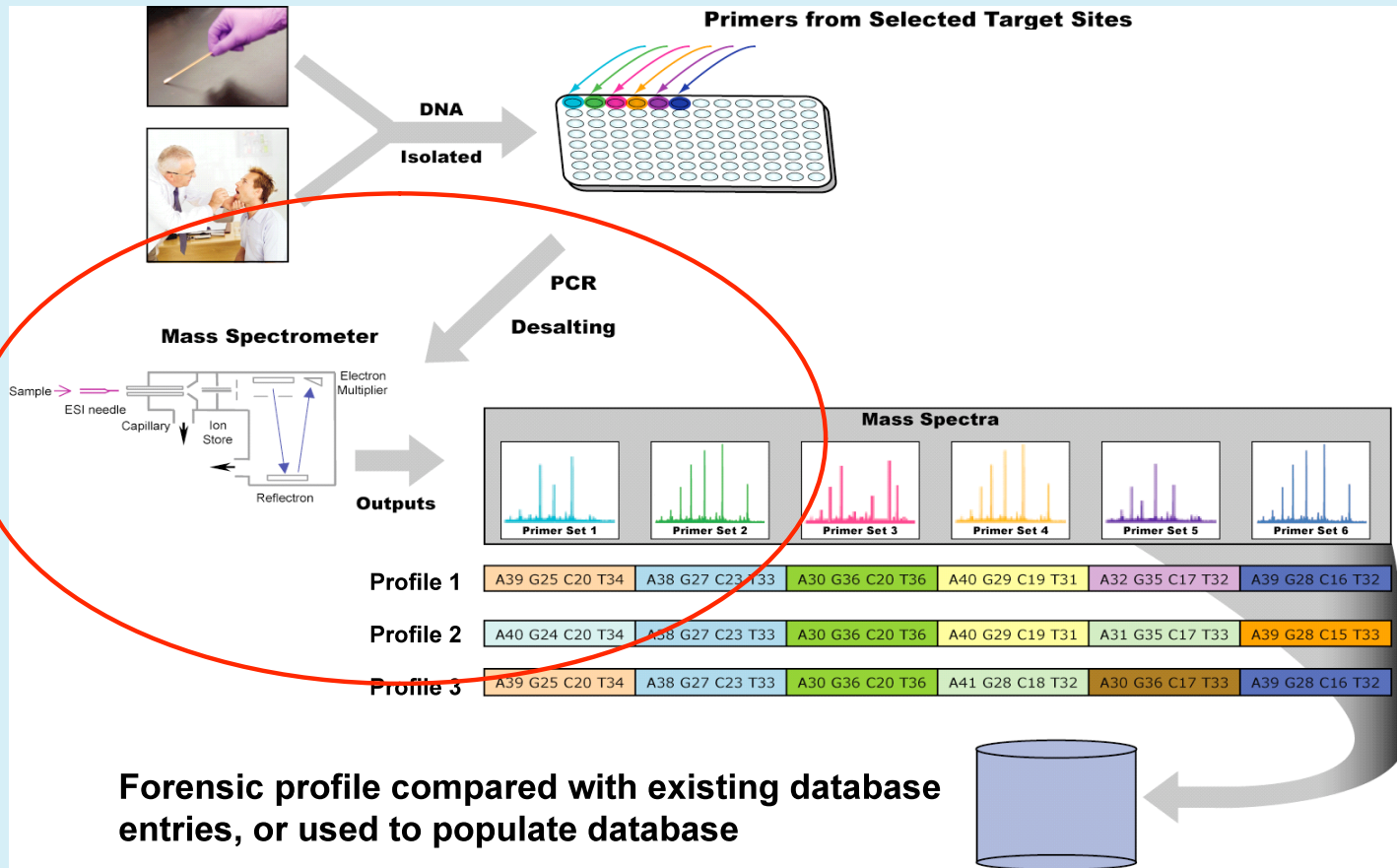

Conclusions

- In general, mass spectrometry is used to “weigh” molecular analytes of interest
- Electrospray ionization is employed as it can promote large, intact oligonucleotides into the gas phase
- Time-of-Flight mass spectrometry is used as it provides accurate molecular weight measurements in a robust, benchtop, instrument format
- As part of the Ibis™ process, amplified DNA is “weighed” with enough accuracy to unambiguously determine base composition [AGCT]
- Base composition profiles can be compared to other profiles and/or databases

Abbreviations and Jargon

APCI	atmospheric pressure chemical ionization	kDa	kilo Dalton(s)
bp	base pair(s)	m/Dm	mass divided by peak width (mass resolution)
CAD	collisionally activated dissociation	m/z	mass to charge ratio
Da	Dalton = atomic mass unit	MALDI	matrix assisted laser desorption ionization
DNA	deoxyribonucleic acid	MSAD	multipole storage assisted dissociation
Ds	double stranded (DNA)	mtDNA	mitochondrial deoxyribonucleic acid
EI	electron impact (ionization)	MW	molecular weight
ESI	electrospray ionization	PCR	polymerase chain reaction
FAB	fast atom bombardment	PD	plasma desorption
FD	field desorption (ionization)	ppm	parts per million
FI	field ionization	QIT	quadrupole ion trap
FTICR	Fourier transform ion cyclotron resonance	Q-TOF	quadrupole-time-of-flight
FTMS	Fourier transform mass spectrometry	rf	radio frequency
FWHM	full width half maximum (used to specify resolution)	SIMS	secondary ion mass spectrometry
GC	gas chromatography	ss	single stranded (DNA)
Hz	Hertz (cycles/second)	TOF	time-of-flight
IRMPD	infrared multiphoton dissociation	TSP	thermospray (ionization)

Questions?

Contact Information

Steven A. Hofstadler, Ph.D.

Ibis™ Biosciences, Inc.

(760) 476-3299

shofstad@ibisbio.com

Note: All images are courtesy of Dr. Steven A. Hofstadler
unless otherwise noted.

Technology
Transition Workshop 